

AIR POWER

SPRING 2002 - Volume 49, Number 1

History



Coalition Air Warfare in the Korean War

1950-1953



~~October 17-18, 2001~~ May 7-8, 2002

Andrews AFB, Maryland, Officer's Open Mess

Presented by the Air Force Historical Foundation and the U.S. Air Force History Office in conjunction with the Historical Foundations and History Offices of the U.S. Army, U.S. Navy and U.S. Marine Corps

AIR POWER

SPRING 2002 - Volume 49, Number 1

History

The Black Cat Squadron <i>Hsichun Mike Hua</i>	4
Sabre Pilot Pickup: Unconventional Contributions to Air Superiority in Korea <i>Forrest L. Marion</i>	20
Bernard Schriever and the Scientific Vision <i>Stephen B. Johnson</i>	30
USAF Logistics in the Korean War <i>William W. Suit</i>	48

Book Reviews

<i>Secretaries and Chiefs of Staff of the U.S. Air Force</i> by George M. Watson, Jr. Reviewed by Walter Boyne	60
<i>Professional Military Education in the United States</i> by William E. Simons, Ed. Reviewed by Edwina Campbell	60
<i>RAF Squadrons</i> by C.G. Jefford Reviewed by AVM W. Harbison	60
<i>Wingless Eagle: U.S. Army Aviation through World War I</i> by Herbert A. Johnson Reviewed by Roger G. Miller	61
<i>U.S. Eyes of Artillery</i> by Edgar F. Raines, Jr. Reviewed by Daniel Mortensen	62
<i>The Last Battle</i> by Ralph Wetterhahn Reviewed by John Sherwood	64
<i>Reconsidering Sputnik</i> by Roger D. Launius, John M. Logdson, & Robert W. Smith Reviewed by Rick W. Sturdevant	64
<i>Fortress Against the Sun</i> by Gene Eric Salecker Reviewed by Scott A. Willey	65
Books Received	66
Coming Up	68
History Mystery	70
Letters, News, Notices, and Reunions	71

For symposium registration materials see page 76

The Air Force Historical Foundation

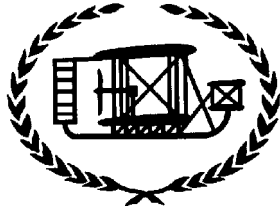

Officers

President

Gen. William Y. Smith, USAF (Ret)

Vice-President

Gen. John A. Shaud, USAF (Ret)

Secretary-Treasurer

Maj. Gen. John S. Patton, USAF (Ret)

Executive Director

Col. Joseph A. Marston, USAF (Ret)

Advisors

Gen. John P. Jumper, USAF

Lt. Gen. John R. Dallager, USAF

Lt. Gen. Donald A. Lamontagne, USAF

Brig. Gen. Ronald T. Rand, USAF

Dr. Richard P. Hallion

CMSAF Frederick J. Finch, USAF

CMSGt. Walt Grudzinskas, USAF

Trustees

Col. Kenneth J. Alnwick, USAF (Ret)

Mr. F. Clifton Berry, Jr.

Lt. Col. Maynard Y. Binge, USAF (Ret)

Gen. Mark E. Bradley, USAF (Ret)

Lt. Gen. Devol Brett, USAF (Ret)

Lt. Gen. William E. Brown, USAF (Ret)

Lt. Gen. Charles G. Cleveland, USAF (Ret)

Lt. Gen. John Conaway, USAF (Ret)

Gen. Bennie L. Davis, USAF (Ret)

Brig. Gen. Michael DeArmond, USAF (Ret)

Gen. Robert J. Dixon, USAF (Ret)

Gen. Michael J. Dugan, USAF (Ret)

Gen. Howell M. Estes, Jr., USAF (Ret)

Lt. Gen. Abbott C. Greenleaf, USAF (Ret)

Mr. John E. Greenwood

Brig. Gen. Brian S. Gunderson, USAF (Ret)

Maj. Gen. John P. Henebry, USAF (Ret)

Col. George A. Henry, Jr., USAF (Ret)

Gen. Robert T. Herres, USAF (Ret)

Dr. I. B. Holley, Jr.

Maj. Gen. Jeanne M. Holm, USAF (Ret)

Lt. Gen. Bradley C. Hosmer, USAF (Ret)

Dr. R. Gordon Hoxie

Brig. Gen. Alfred F. Hurley, USAF (Ret)

Brig. Gen. James A. Jaeger, USAF (Ret)

Gen. David C. Jones, USAF (Ret)

Maj. John Kreis, USAF (Ret)

Lt. Col. Kathy La Sauce, USAF (Ret)

Maj. Gen. Charles D. Link, USAF (Ret)

Lt. Col. Donald S. Lopez, USAF (Ret)

Hon. Hans Mark

CMSGt Norman A. Marous, USAF

Hon. John L. McLucas

Col. Kenneth Moll, USAF (Ret)

Gen. Thomas S. Moorman, Jr., USAF (Ret)

Col. Helen E. O'Day, USAF (Ret)

Hon. Verne Orr

CMSGtAF Sam E. Parish, USAF (Ret)

Maj. Gen. John S. Patton, USAF (Ret)

Maj. Gen. Ramsay D. Potts, USAF (Ret)

Brig. Gen. Edward W. Rosenbaum, USAF (Ret)

Gen. Bernard A. Schriever, USAF (Ret)

Gen. John A. Shaud, USAF (Ret)

Gen. Jacob E. Smart, USAF (Ret)

Gen. William Y. Smith, USAF (Ret)

Dr. George K. Tanham

Col. Robert E. Vickers, Jr., USAF (Ret)

MSGt. Charles J. Warth, USAF (Ret)

Col. George R. Weinbrenner, USAF (Ret)

Col. Sherman W. Wilkins, USAF (Ret)

Maj. Gen. Richard A. Yudkin, USAF (Ret)

Air Force Historical Foundation
1535 Command Drive – Suite A122
Andrews AFB, MD 20762-7002
(301) 981-2139
(301) 981-3574 Fax

Contributing Members

The individuals and companies listed are contributing members of the Air Force Historical Foundation. The Foundation Trustees and members are grateful for their support and contributions to preserving, perpetuating, and publishing the history and traditions of American aviation.

Benefactor

Mrs. Ruth A. (Ira C.) Eaker Estate

Patron

Maj. Gen. Ramsay Potts

Sponsors

Maj. Gen. William Lyon

Maj. Gen. John S. Patton

General Rawlings Chapter, AFA

Brig. Gen. Edward W. Rosenbaum, USAF (Ret)

Gen. William Y. Smith

Tomlinson Family Foundation Inc.

Donors

Mr. John F. Donahue

Emerson Electric

Rockwell International

Quesada Foundation

Gen. Bernard A. Schriever

Supporters

The Aerospace Corporation

Allied-Signal Aerospace Corporation

Arthur Metcalf Foundation

CSX Corporation

Brig. Gen. Brian S. Gunderson

Maj. Gen. John P. Henebry

Gen. & Mrs. Robert T. Herres

Maj. Gen. Harold E. Humfeld

McDonnell Douglas Foundation

Maj. Gen. Kenneth P. Miles

Northrop-Grumman Corporation

Mr. William O'Rourke

Mr. James Parton

Mr. George Pendelton

Pratt & Whitney

Gen. D. C. Strother

United Technologies

Capt. William C. Ward

Maj. Gen. Richard A. Yudkin

Annual Contributing Members

ANSER

ARX, Inc.

ASTECH/MCI Manufacturing, Inc.

Beech Aircraft Corporation

Boeing Defense & Space Group

General Electric Company

Instrument Systems Corp.

Litton Industries

Lockheed Martin Corp.

The Mitre Corporation

Northrop Corporation

Vinell Corporation

AIR POWER *History*

The Journal of the
Air Force Historical Foundation
Spring 2002 Volume 49 Number 1

Publisher

Brian S. Gunderson

Editor

Jacob Neufeld

Technical Editor

Robert F. Dorr

Book Review Editor

Scott A. Willey

Layout and Typesetting

Richard I. Wolf

Advertising

Mark D. Mandeles

Circulation

Richard I. Wolf

Air Power History (ISSN 1044-016X)

is produced in March, June, September,
and December by the Air Force Historical
Foundation.

Prospective contributors should consult the
GUIDELINES FOR CONTRIBUTORS at
the back of this journal. Unsolicited manu-
scripts will be returned only on specific
request. The Editor cannot accept responsi-
bility for any damage to or loss of the man-
uscript. The Editor reserves the right to
edit manuscripts and letters.

Address **Letters to the Editor** to:

Air Power History
P.O. Box 10328
Rockville, MD 20849-0328
e-mail: neufeldj@starpower.net

Correspondence regarding missed issues
or changes of address should be addressed
to the **Circulation Office**:

Air Power History
P.O. Box 151150
Alexandria, Virginia 22315
Telephone: (703) 923-0848
Fax: (703) 923-0848
e-mail: airpowerhistory@yahoo.com

Advertising

Mark Mandeles
8910 Autumn Leaf Ct.
Fairfax, VA 22301
(703) 426-5147; fax 426-5149
e-mail: mandelm@erols.com

Copyright © 2002 by the Air Force
Historical Foundation. All rights reserved.
Periodicals postage paid at Lexington, VA
24450 and additional mailing offices.

Postmaster: Please send change of
address to the Circulation Office.

FOUNDATION WEB HOMEPAGE: <http://home.earthlink.net/~afhf>
E-Mail: afhf@earthlink.net

This issue's lead article, "Black Cat Squadron," by Gen. Hsichun Mike Hua, ROCAF (Ret.), is a first-hand account of the joint U.S.-ROC U-2 operations over mainland China. General Hua describes in detail the challenges posed and met, often at great cost in blood. Ironically, the intelligence gathered by the Nationalist pilots enabled the U.S. to recognize Communist China.

Forrest Marion's "Sabre Pilot Pickup," tells of the contributions made by air rescue during the Korean War. This unique service recovered enemy planes, saved American pilots "to fly and fight another day," and reassured our pilots that their nation would do everything possible to rescue them.

"Bernard Schriever and the Scientific Vision," by Stephen Johnson shows how General Schriever incorporated the ideas of scientists and engineers into the development of missiles and space systems. Moreover, he incorporated these ideas into management procedures that were later adopted by the Department of Defense and the aerospace industry.

William Suit's account, "USAF Logistics in the Korean War," proclaims that "no combat sorties could have been flown without the support of the 'logistics tail.'" He persuasively supports this assertion by documentation and detailed examples.

After two years as book review editor, we bid a fond farewell to Dr. Michael Grumelli and wish him continued success on the Air Command and Staff College faculty at Maxwell AFB, Alabama. His successor is Col. Scott A. Willey who retired from the USAF in 1995, after more than twenty-seven years on active duty. Colonel Willey served in several weapons systems acquisition positions; held staff jobs at Eighth Air Force, Systems Command, Strategic Air Command, USAF headquarters, and the Office of the Secretary of Defense. He commanded a KC-10 maintenance squadron and taught at the Industrial College of the Armed Forces. His lifelong interest in aeronautical and military history brought him to the National Air and Space Museum in 1977, as a docent at the museum's storage and restoration facility. He has given tours for sixteen years and, since retirement, has served as a volunteer working on restorations, research, and preparation for movement of the collection to the new Hazy Center at Dulles International Airport.

Readers will notice that book reviews are now listed on the contents page for easier access. The usual departments include upcoming events, the History Mystery, letters, notices, news, and reunions. Readers should note especially the "Rescheduled Symposium" notice and registration form on page 76. Save the dates May 7 and 8, 2002, at Andrews Air Force Base, Maryland, for "Coalition Air Warfare in the Korean War." Sign up now.

At press time we learned that the Confederate Air Force had been renamed. [See *Air Power History*, Vol. 48, No. 4, p. 70.] In a vote by the membership, announced in December 2001, 54 percent voted for the new name—Commemorative Air Force.

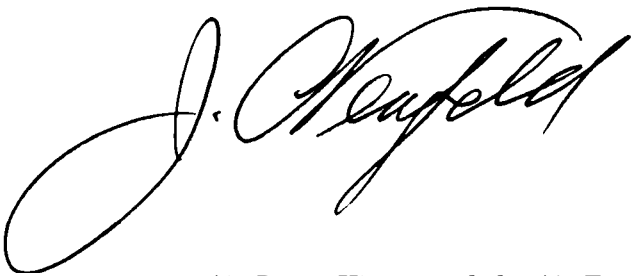

Air Power History and the Air Force Historical Foundation disclaim responsibility for statements, either of fact or of opinion, made by contributors. The submission of an article, book review, or other communication with the intention that it be published in this journal shall be construed as prima facie evidence that the contributor willingly transfers the copyright to *Air Power History* and the Air Force Historical Foundation, which will, however, freely grant authors the right to reprint their own works, if published in the authors' own works. In the case of articles, upon acceptance, the author will be sent an agreement and an assignment of copyright.

THE BLACK CAT SQUADRON





Hsichun Mike Hua

(Overleaf) The U-2 pilots were trained in the U.S. on bases like this one.

**WHEN THE ...
U-2 BECAME
OPERATIONAL IN
1956, ...
EISENHOWER
FAVORED
RECRUITING
FOREIGN
NATIONALS
TO PILOT THE
AIRCRAFT**

**THE DEPUTY
COMMANDER
OF [THE]
4028TH SRS,
CAME TO
TAIWAN AND
BROUGHT SIX
OF US ... TO
LAUGHLIN
AFB**

The government of the Republic of China (ROC) left mainland China in 1949 for Taiwan. Since then the Chinese Communists threatened the ROC in Taiwan and the offshore islands. This threat increased after the Korean War ceasefire. At the same time, former President Chiang Kai-shek never gave up hope of returning to the mainland to liberate his compatriots. In the 1950s, the ROC Air Force frequently conducted photo reconnaissance flights over the coastal areas opposite the Taiwan Strait with aircraft provided by the United States.

When the Lockheed U-2 became operational in 1956, President Dwight D. Eisenhower favored recruiting foreign nationals to pilot the aircraft.¹ ROCAF pilots were considered the best candidates to execute these missions over Communist China, but the ROC U-2 pilot selection did not begin until 1959.

In November 1956, six Nationalist Chinese pilots arrived at Lackland Air Force Base (AFB), Texas, to learn English, followed by RB-57A flight training at Wendover AFB, Utah. Two RB-57As were sent to Taoyuan Air Base (AB), Taiwan, and a special joint ROCAF/USAF squadron was organized. Overflight missions began on December 6, 1957, but were stopped two months later when an RB-57A, piloted by Kunhua "Charles" Chao, was shot down over Shantung province. He could not fly high enough to evade an attack by MiG-19s. Afterwards the rest of the pilots returned to the U.S. for additional training on the improved RB-57D.

When the Chinese Communists (ChiComs) unleashed a massive bombardment of the offshore island of Quemoy in August 1958, Chinese fighters from both sides engaged in air battles; thirty-one MiG-17s and one F-86 were lost. The U.S. 7th Fleet dispatched ships to provide logistics support to ROC. The Taiwan Strait was on the verge of all-out war. Because ROC reconnaissance pilots were still training at Laughlin AFB, American U-2 pilots had to fly over the mainland from Okinawa. It was probably at this moment that the U.S. began to seriously consider recruiting ROC pilots to fly the U-2.

I was the operations officer of an F-86 squadron stationed at Pingtung AB. A telephone call from the wing commander's office one afternoon in March 1959, ordered me to report immediately to ROCAF headquarters in Taipei. I caught a night

train to Taipei and reported to headquarters the next morning. The office of the Deputy Chief of Staff for Intelligence also summoned eleven other pilots from various squadrons. We flew to Okinawa that afternoon for physical examinations, including a test in the high altitude chamber, pressurized to 40,000 feet.

Major Joe Jackson, the deputy commander of 4028th Strategic Reconnaissance Squadron (SRS), came to Taiwan and brought six of us: Shihchu "Gimo" Yang, Taiyu "Tiger" Wang, Yaohua Chih, Huai Chen, Chungkuei Hsu and me, to Laughlin AFB. The following week the ground school started. To our surprise, the subjects taught were navigational aids, air traffic control, and some very basic celestial navigation. Up until this moment, we thought that we were in the U.S. for flight training to serve as backup for the other group of ROCAF RB-57D pilots trained here. We never knew there was a reconnaissance aircraft other than the RB-57D. Why had the instructors never mentioned this aircraft?

A few weeks later, we received partial pressure suits at Carswell AFB, near Fort Worth, Texas, and then went through a low-pressure chamber at an altitude of 80,000 feet. The officer there told us that without a pressurized suit a man's blood would boil and he would die instantly at above 65,000 feet. The test confused me even more, since RB-57D could never fly that high.

I remember that I had once scrambled from Pingtung AB to intercept an unidentified object over mainland China coming toward Quemoy in September 1958. Ground control interception (GCI) guided us to the intercept point, but we could not find any enemy aircraft. Finally, GCI directed us to abort the mission because the object's altitude was around 70,000 feet and interpreted it as a balloon. They had never heard of any aircraft that could fly so high.

After we got back to Laughlin, the instructors began to introduce us to the glider-like U-2, using several cockpit schematics as reference. There was no handbook or flight manual and our handwritten notes could not leave the classroom. This was the first lesson of belonging to a secret project. There was no two-seater U-2 available at that time, so every pilot's first flight was solo. The U-2 is a peculiar jet airplane. The pilot has to push the control wheel to lift the tail wheel off the ground during the takeoff roll, to avoid becoming prema-

General Hsichun Mike Hua, ROCAF (Ret.) was born in mainland China and later moved to Taiwan in 1948. He graduated from the Chinese Air Force Academy, and then served as a military pilot in Taiwan for fifteen years. In 1964, after completing many U-2 missions over the mainland China, he pursued a graduate degree in aeronautical engineering at Purdue University. He earned a Ph. D. and then worked for Cessna and Lockheed Aircraft companies. In 1970, he returned to Taiwan to participate in establishing an aircraft industry there. Some of his honors include the Engineering Medal from the Society of Engineers in the Republic of China, Associate Fellow in AIAA, the Outstanding Aerospace Engineer Award from Purdue University, the Distinguished Flying Cross from the U.S. Air Force, and many medals from the Republic of China's armed forces.

THE U-2 IS ALSO A MOST DIFFICULT AIRCRAFT TO LAND. [IT] WILL GLIDE 1,000 FEET DOWN THE RUNWAY, WHILE DESCENDING ONE FOOT

A U-2, FORCED-LANDING IN JAPAN, CAUSED A LOT OF PUBLICITY

TWO U-2Cs ARRIVED IN TAOYUAN IN JANUARY 1961. THE COVER STORY WAS THAT THE ROCAF HAD PURCHASED THE AIRCRAFT

turally airborne. Then the pilot holds the airplane level, while accelerating to the takeoff speed. After becoming airborne, the pilot has to pull the nose up to about 75 degrees, almost immediately, to avoid exceeding the aircraft's speed limit. Because the engine is so powerful with respect to the weight of the aircraft, all these maneuvers proceed swiftly. It was quite a challenge for a new pilot to handle. Chungkuei Hsu did not handle it well on his first fight. He pushed the control wheel too late and also too much while the aircraft was already inadvertently airborne, and crashed the aircraft on the runway. He transferred to Nellis AFB, Nevada, to learn to fly the F-100.

The U-2 is also a most difficult aircraft to land. The excellent glide ratio, in addition to the ground effect, makes the aircraft float over the runway for a very long distance. The aircraft will glide 1,000 feet down the runway, while descending one foot. The approach altitude over the threshold is critical. A standard procedure was already in effect when we arrived. An experienced pilot positioned himself at the end of the runway. As the U-2 approached the threshold, the pilot on the ground told the pilot in the cockpit the exact altitude of the aircraft above the runway to avoid an overshoot. In this respect, I was lucky when I made a midnight deadstick landing at a small airport, without another pilot's support.

That was my seventh training flight. I had left Laughlin AFB around 8:30 PM on August 3 and planned to fly to Ogden, Utah, and back, practicing celestial navigation. When I reached Ogden, I was gratified that my first night flight over the U.S. covered more than 1,100 miles and I did not get lost. Shortly after passing Delta, Utah, on the way back to Laughlin, the engine flamed out. The clock showed 10:28 PM local time. The engine cannot restart above 35,000 feet and the aircraft cannot tolerate a fast descent from above 70,000 feet. The only action I could take was to maintain the aircraft gliding on course.

It was cloudy over the Rocky Mountains. Upon reaching 35,000 feet, I tried to relight the engine three times, using different procedures, but all failed. I knew the mountain peaks were around 13,000 feet in that area, but clouds blocked my view. The aircraft continued losing altitude. It could hit the mountain at any time. Suddenly, I saw lights at the eleven o'clock position. I had come out of the clouds to find that I was gliding along a narrow valley between tall mountains. The lights on the ground meant there must be an inhabited area. I might be able to find a flat field for a forced landing. As I drew nearer to the lights, I saw an airport and made a smooth touchdown on the runway. The landing gear did not extend fully. The belly scratched the pavement. The left wing tip struck the shoulder of the runway. The aircraft went into a ground loop and came to rest in one piece. I went to the only lighted building at the airport. An Asian, wearing a strange pressure suit, walked up to the door at midnight. It took me a little while, using my Chinese-accented English, to

fully explain the situation to the two people in the building, who doubtless thought a UFO had landed. They had never heard of a U-2. As for me, I had never heard of Cortez, Colorado. Neither the town, much less its airport, appeared on my map. The next morning, the 4080th SRW sent in a team headed by Maj. Julian P. Anderson. He found a broken fuel tubing that drained all the fuel on board and caused the engine to flame out. They loaded the U-2 on a C-124 and shipped it back to Laughlin. Months later, I received a USAF Distinguished Flying Cross.

We five ROCAF pilots completed the training in September 1959, and returned to Taiwan shortly thereafter. A U-2, forced-landing in Japan, caused a lot of publicity at just about the time we arrived in Taiwan. An SA-2 had shot down Gary Powers over the USSR in May 1960. These incidents made the U-2 a world-renowned spy aircraft. We were ordered to report to our old squadrons. It was not until almost a year later, in the fall of 1960, that we returned to Laughlin for further proficiency training.

Two U-2Cs arrived in Taoyuan in January 1961. The cover story was that the ROCAF had purchased the aircraft, that bore the Chinese national insignia. The organization, under the command of ROCAF headquarters, was the "Weather Reconnaissance Research Section." To avoid being confused with other air force organizations stationed in the Taoyuan AB, the section became the 35th Squadron with the Black Cat as its insignia. On the American side, there was Detachment H. All U.S. personnel were ostensibly employees of the Lockheed Aircraft Company. The Chinese participants consisted of five pilots, a few support people and the squadron commander, a ROCAF colonel. ROCAF and U.S. representatives in Taipei, signed a joint agreement, codenamed "Razor."

The U-2C had a more powerful engine, the J75, than the U-2A. Pilots and the whole newly organized team needed time to become familiar with the new equipment. The operational training started right after the aircraft was reassembled and checked out. To avoid detection, we always flew eastward under 40,000 feet, exceeding the ChiCom's radar coverage.

On March 19, Yaohua Chih flew back after a four-hour night flight and continued to practice touch and go before landing. The weather was good with glittering stars and no moon. Bob Ericson, a U.S. pilot, and Tiger Wong were at the end of the runway in the "mobile"—an automobile equipped with ultra high-frequency (UHF) or very high frequency (VHF) radios, that are operated by a pilot to assist the pilot in the aircraft to make safe take-offs and landings. The U-2 accelerated to lift up after touching the runway. They saw the red collision light on the aircraft's tail suddenly deviate to left of the runway. Without any emergency message being transmitted by the pilot, the aircraft dropped to the ground. An explosion was followed with a burst of flame. Rescue teams rushed to the



The author in a partial pressure suit. (Photo courtesy of the author.)

I TURNED THE AIRCRAFT TO A HEADING OF 165 DEGREES AND SWITCHED OFF ALL THE UNNECESSARY ELECTRICITY

site, but could not reach the cockpit in time to save the pilot. The cause of this accident was not revealed.

Another U-2C arrived at Taoyuan. The Black Cat Squadron was ready to penetrate the Bamboo Curtain. However, President John F. Kennedy announced on January 25, 1961: "I have ordered that the overflights not be resumed, which is a continuation of the order given by President Eisenhower in May of last year."² However, U-2s piloted by the ROCAF could fly over the mainland to collect intelligence because the Republic of China was at war with the People's Republic of China. Penetration missions did not occur until January 1962.

Washington planned the missions based on the priority of the targets and the weather forecast and sent the encrypted mission plan to the U.S. manager of the 35th squadron. The commander of the squadron then submitted it through General Fu-en I to Ching-kuo Chiang, vice chair of the National Security Bureau (NSB) in the President's

office, for concurrence. Only a few times did the ROC ask to cover targets for its own needs.

The ChiCom's early warning radar had good coverage all over mainland China and monitored the U-2 at all times. Our COMINT station, located between Taipei and Taoyuan, intercepted ChiCom's air defense communication. Although the U-2 kept absolute radio silence during the mission, we knew our aircraft's exact position through COMINT interception of the ChiCom's communication.

At the end of each mission, a C-130 carried the exposed film to Japan to be developed. The ROC NSB received a copy. To avoid possible damage during delivery, the ROCAF photo laboratory in Taoyuan expanded to cope with the requirements for processing U-2 film and to make enough copies for both parties. Photo interpreters at Taoyuan made the preliminary assessment. Photo reconnaissance required good weather over the target area. Because the number of photos from each U-2 mission was enormous, it took time between missions to analyze them. Thus, the rate of dispatched missions was not very high. Huai Chen flew the first mission on January 13, 1962. Gimo Yang flew the second mission on February 23 and I flew the third mission on March 17. Tiger Wang flew the fourth mission on March 26. We spent a lot of time waiting for good weather.

The missions covered the vast interior of the Chinese mainland, where almost no aerial photographs had ever been taken. All ROCAF reconnaissance aircraft, including the RB-57D, could reach only the coastal provinces. The B model camera mounted on U-2 could take seven oblique and vertical high-resolution photos sequentially from horizon to horizon. Each mission brought back an aerial photographic map of roughly 100 miles wide by 2,000 miles long, which revealed not only the precise location of a target, but also the activities on the ground. In addition to the camera, wide band ELINT System 3 and System 6 receivers on board recorded a large amount of new electromagnetic emissions in and above VHF frequencies, including radar signals excited by U-2. The intelligence collected by these U-2 flights was tremendous.

The ChiComs did not ignore the intrusion. They always sent MiGs to intercept and follow the U-2s, although the MiGs could not reach the altitude at which the U-2 flew. The MiGs awaited for the opportunity when an equipment malfunction would force the U-2 to descend.

On August 11, 1962, I took off at 5:06 AM and headed North on my third overflight mission. The planned course was to enter over Tsingtao, turn right, and pass Dairen toward the northeast provinces. After covering many targets over that area, I planned to fly along the coast to Tientsin and Peking. I was to then turn right to Changchiakou and turn left to cover targets on the way back to Taoyuan.

Peking was the most heavily defended area in the whole PRC and no ROCAF aircraft had flown

Aerial photo of Peking taken in August, 1966. (Photo courtesy of the author.)



THE AIR-CRAFT WAS ABOUT 1,200 MILES AWAY FROM HOME BASE. I HAD TO FLY IN THIS CONDITION FOR NEARLY THREE HOURS

BY USING ADF AS A NAVIGATIONAL AID, I FLEW BACK TO TAOYUAN

near that area since an RB-57D had done it on October 7, 1959, but did not return. After passing Peking on the right, I felt relieved. However, the aircraft did not allow me to relax for long. The generator suddenly quit working during the turn over Changchiakou. I tried to reset the generator but could not. Without the generator the autopilot would not work. Without the autopilot, the U-2 is very difficult to control manually at high altitude. The flight controls are sluggish and heavy and the airspeed ranges from overspeed buffet to stall is less than ten knots. Pilots generally refer to that flight condition as the “coffin corner” in the aircraft speed-altitude envelope. Any distraction to the pilot in controlling may let the aircraft exceed its speed limit. Flying too fast could cause the airframe to disintegrate. A stall could cause loss of control or engine flameout. The aircraft is easier to handle at a lower altitude. The MiGs and their contrails beneath persuaded me not to reduce altitude. The camera had already stopped working following generator failure. It made no sense to fly the planned course. I turned the aircraft to a heading of 165 degrees toward Taoyuan and switched off all the unnecessary electricity consuming equipment to save the battery for landing. The aircraft was about 1,200 miles away from home base. I had to fly in this condition for nearly three hours until reaching the Taiwan Strait.

The weather became overcast when the aircraft reached the southern part of Shantung province. I began to worry. The only onboard directional instrument was the magnetic compass, which provided only approximate direction. Without high

altitude wind information, the aircraft might drift off course, way out over the Pacific Ocean. After I struggled for over two hours, the clouds started to break. Fortunately, through an opening in the clouds I spotted, with the driftsight, three small islands which looked like the Tachen Islands. I had left the mainland. I could descend to a lower altitude to ease the workload of controlling the aircraft. By using ADF (automatic detection finder) as a navigational aid, I flew back to Taoyuan. I was exhausted when I climbed out of the cockpit at the end of the runway.

From the picture taken over the Peking area, we found three empty SA-2 sites. Years later I read a book published by the Chinese communists. It stated: “In the first six months of 1962, ROCAF U-2s intruded 11 times, and had flown over almost all regions of China except Tibet and Sinkiang. The PRC Air Force decided in June to move all three operational missile battalions in the PRC from the area around Peking to the areas where they expected the U-2 [to pass] over.”³ I realized that was the reason I did not encounter any SA-2s over Peking.

A month later, on September 9, 1962, Huai Chen was assigned to execute his fourth mission. I was his backup and would carry out the mission if for some reason he could not. Otherwise, the backup helps with the preflight check and operates the “mobile.” Takeoff was at 7:00 AM. When the squadron commander did not wake me up at 4:00 AM, it meant Chen would fly that mission, since the pilot requires three hours to eat breakfast, listen to the briefing, put on his pressure suit,

WE PRACTICED "NEED TO KNOW." THIS LIMITED THE INFORMATION THAT WE KNEW IN CASE OF CAPTURE

and breathe pure oxygen for more than an hour before takeoff. I went to the aircraft to perform the preflight check. Chen, wearing his pressure suit and carrying a portable oxygen bottle and maps, walked down from a van near the U-2. I helped him get into the cockpit, read the preflight checklist and closed the canopy. He then started the engine and taxied out to take off. After the mission aircraft took off, the backup pilot would stay in the waiting room until someone from the command post informed him that the mission aircraft was approaching to land. Then the backup drove the "mobile" to meet the aircraft at the end of the runway. We practiced "need to know." Pilots knew only what was necessary for them to execute their missions. This limited the information that we knew in case of capture. At about 10:00 AM the squadron commander came to tell me, without explanation, that I did not have to wait any more.

The PRC broadcast the same day that a U-2 crashed in eastern China. There was no information as to why the U-2 crashed, nor whether the pilot survived. Many people involved in the special detachment did not believe that the PRC had the SA-2 that killed Huai Chen. The only evidence we obtained was that ROCAF COMINT had not intercepted any position report on Chen's aircraft reaching Nancheng. But Huai Chen had been shot down by an SA-2.

Overflight missions stopped until a radar-warning receiver (RWR) arrived in late November. System 12 could detect the SA-2's fire control radar signal. A ground radar acquisition results in a white strobe light on a two-inch indicator and a white warning light in the cockpit, and a warning beeps in the headset. The direction of the strobe shows the relative bearing of the radar site. The length represents the strength of the signal, the longer the strobe, the nearer the aircraft to the SA-2 site. A red light, along with high rate warning beeps in the headset, indicates that the aircraft is approaching the SA-2 range and the enemy radar has switched from acquisition to tracking mode. The missile may be already on its way. The indicator has no scale and does not tell the distance between the SA-2 site and the aircraft. The pilot has no way to decide the best maneuver to evade. The whole instrument seemed very primitive.

I flew the first mission in a new replacement U-2, after System 12 had checked out. I was fully aware of the risk involved in this mission. Mounting System 12 on the aircraft meant that the PRC had the SA-2. Maj. Rudolph Anderson, our U-2 instructor during flight training at Laughlin AFB, was shot down by an SA-2 over Cuba on October 27, 1962, meaning that his aircraft either did not have System 12, or the RWR did not work. Anyway, I had to take this system to test its feasibility over hostile territory. On December 6, I took off at 6:15 AM from Taoyuan and flew directly toward the northeast provinces. After completing the photo reconnaissance over the PRC, I flew to North Korea to cover targets

there. I flew south, almost reaching the 38th parallel, when System 12 started to show an indication. The light strobe pointed toward six o'clock, showing that I was headed away from the radar site. I did not take any evasive maneuvers.

Reconnaissance over the PRC resumed using System 12 as a shield against SA-2 attack. Fortunately the ChiComs did not have enough operational SA-2 batteries to cover the entire mainland, but they had to move them around. Our mission planning consequently needed to consider how to avoid passing over the suspect missile sites. The reconnaissance mission became a hide-and-seek game.

The U.S. and ROCAF did not want to stop the overflight missions, even after losing an aircraft over the enemy territory. The U-2 joint project would continue for quite some time. However, we had only three pilots available and it would not last long, based on the attrition rate. New pilots soon arrived for training. Nanping "Terry" Lee and Changdi "Robin" Yeh completed the training at Davis-Monthan AFB, Arizona, and returned to Taoyuan in July 1963. The combat fatigue of the pilots resulted in a policy that a detachment pilot could only complete ten overflight missions.

Meanwhile, the ChiComs built giant nuclear reactors and ballistic missile test sites in the Lanchow-Paotow-Chiuchuan area. When would the PRC have a nuclear ballistic missile capability? A U-2 overflight could provide the answer. However the operational range of the U-2C was marginal for this mission and once there could not devote enough time to cover the targets. Mission planning began to consider using a base in South Korea.

On the evening of March 27, 1963, Tiger Wang and I rode in a C-130 from Taoyuan to Kunsan AB, a small advanced airfield in South Korea. An American pilot arrived in a U-2. Tiger took off in the early morning and the rest of us rode back to Taiwan in the C-130. Tiger arrived at Tingsing near Chiuchuan around 10:55 AM. System 12 suddenly "came to life." The strobe pointed in the one o'clock direction. He made a left turn to fly away from the SA-2 site. A few moments later the strobe disappeared. Then he continued the 360-degree turn intending to fly back to original course. Just before he turned back to the course, System 12 flashed again. This time the strobe pointed to eleven o'clock. Thinking there was another site nearby, he maneuvered to the right and the SA-2 radar lost his track. After System 12 stopped flashing and the aircraft came out of the turn, Tiger could not find where he was and how to get back on course. He then flew directly toward Taiwan. Weather did not cooperate on the way back. Overcast blocked the view of the ground. He finally found he was over the Pratas (Tungsha) Islands in the Pacific Ocean.⁴ The U-2 landed at Taoyuan almost an hour later than scheduled.

On May 28, 1963, Gimo Yang flew a mission to the northeast provinces. The flight plan was to cover the area along the Sino-Soviet border and

WHEN WOULD THE PRC HAVE A NUCLEAR BALLISTIC MISSILE CAPABILITY? A U-2 OVERFLIGHT COULD PROVIDE THE ANSWER

OVERFLIGHT MISSIONS STOPPED UNTIL A RADAR-WARNING RECEIVER ARRIVED IN LATE NOVEMBER. [THIS] MEANT THAT THE PRC HAD THE SA-2.

ON NOVEMBER 1, 1963, ROBIN YEH MADE HIS THIRD OVER-FLIGHT MISSION. HE ... ESCAPED THE FIRST MISSILE, BUT THE SECOND MISSILE TORE OFF HIS RIGHT WING. ROBIN YEH WAS IMPRISONED FOR TEN YEARS

THE...ENGINE OFTEN FLAMED OUT WHILE THE AIRCRAFT ASCENDED... TESTS REVEALED THAT THE TEMPERATURE GRADIENT, FROM 40,000 TO 60,000 FEET, OVER TAIWAN WAS DIFFERENT FROM THAT IN MOST PARTS OF THE WORLD

North Korea, and to land at Kunsan AB. At the end of the mission, the weather was bad, with very low ceiling. Gimo had difficulty finding the landing strip with the only navigational aid, ADF, available. The engine stopped for lack of fuel when the aircraft was still rolling down the runway after landing.

Tiger's mission made the ChiComs aware that the U-2 must have equipment that can detect SA-2 fire control radar. Each time they turned on their acquisition radar, Tiger started to fly away from the site. They realized that the U-2 never came within missile range, approximately twenty-one miles. This could not be sheer coincidence. They began to contemplate countermeasures.⁵

Consequently, the ChiComs decided not to turn on their radar until the U-2 reached missile range, to prevent the aircraft from having enough time to evade. They tried shortening the procedure time from acquisition to fire. The fire control radar was not to turn on until the U-2 was within forty miles of the site, instead of seventy miles as before. They tried the new procedures on June 3, 1963, over the area near Lanchow and failed again. This time I was the pilot. I made two S turns to evade two successive warnings. Further reducing the procedure time did not work either when Terry Lee flew on September 26 over the same area. They turned the radar on and off seven times. Terry maneuvered successfully without flying into missile range.

The ChiComs continued to seek for ways to shorten the time from acquisition to firing. The missile guidance uplink requires two minutes to warm up, which can be in parallel with the acquisition by using a dummy antenna. They also deployed all four operational batteries close to each other to form a wide SA-2 firing front in an area frequently traversed by U-2. The U-2 would have no space to escape when coming into this front.⁶

On November 1, 1963, Robin Yeh made his third overflight mission. He took off around 7:00 AM from Taoyuan to the northeast and climbed to an altitude above contrails. Then he turned to the northwest toward the Langchow-Chiuchuan area. He completed the major part of his mission deep into the northwest interior of the mainland. On the way back, he reached the position where he could see the Taiwan Strait coastline in good weather. System 12 suddenly flashed along with the high rate warning beeps in the headset. He started evasion and escaped the first missile, but the second missile tore off his right wing followed by an explosion, which wounded his legs. He managed to eject from the cockpit and pull his parachute D-ring. Shortly after landing, he passed out due to excessive bleeding. When he regained consciousness, he found himself in a mainland hospital. A ChiCom surgeon had removed fifty-nine missile fragments from his legs. Robin Yeh was imprisoned for ten years, including the first seven years in solitary confinement. In desperation, he attempted suicide by taking an overdose of sleeping pills. The warden found him unconscious,

rushed him to the hospital and extended his sentence until 1977.

At the beginning of 1964, the Black Cats ran out of luck. With the newly upgraded fuel control, the J75 engine often flamed out while the aircraft ascended through the stratosphere. Although the engine could be relit after descending to below 35,000 feet, some overflight missions inevitably aborted. There was a requirement that each pilot fly the aircraft once a week to maintain proficiency. Engine reliability remained a critical concern. Terry almost landed on a riverbed, even though he tried to relight the engine several times during a training flight. The 35th squadron was also short of pilots. The first group of pilots had all completed their assignments in 1964. I attended Purdue University to pursue graduate education. Gimo became the squadron commander. Tiger transferred to the ROCAF to fly RF-101s.

The newly selected pilots, Shichuen "Johnny" Wang and Tehpei "Sonny" Liang, reported to the squadron in January after they completed A-model training at Davis-Monthan AFB. They next started their operational training in the C model. Unfortunately, Sonny Liang was unable to fly an overflight mission. On March 23, Sonny flew a training mission. The four-hour flight plan was from Taoyuan along the Taiwan Strait to the South China Sea and back. Along this course, the ELINT system on board could collect some enemy intelligence. Without any emergency message, the U-2 crashed into the sea. An instrument in the command post, "Birdwatcher," monitored the aircraft based on single side band (SSB) telemetry. The aircraft experienced excessive motion during a turn at high altitude that might have caused structural failure. A fishing boat recovered Sonny's body and parachute near the mainland coast. Sonny might have ejected from the cockpit after losing aircraft control and collided with the airframe that made him unconscious while dropping into the ocean.

During the first five months of 1964, Terry Lee was the only pilot qualified for overflight missions. Only one mission succeeded. At the same time a U-2 detachment temporarily stationed at Cubi Point in Philippines reported that they had no flameout problems. Terry went to Cubi Point and flew from there.

In June, a Lockheed test pilot came to Taiwan and flew with an instrumented engine. The tests revealed that the temperature gradient, from 40,000 to 60,000 feet, over Taiwan was different from that in most parts of the world. A new power setting solved the flameout problem.

Meanwhile, the ChiComs continued to develop electronic countermeasures to defeat System 12. Inspecting the wreckage of Robin Yeh's U-2, they found the damaged System 12. They analyzed the functions of its various components and designed their first ECM equipment accordingly. The equipment utilized a different radar frequency to search for the target. The fire control radar turned on only when the U-2 reached missile range. The time from turning on the fire control radar to the firing

**ON JULY 7,
1964, TERRY
TOOK-OFF
FROM CUBI
POINT**

**THE COM-
MAND POST
IN TAOYUAN
SUDDENLY
HEARD
TERRY'S
EXCITED
VOICE OVER
THE SSB
RADIO**

**THE CHICOMS
HAD FIRED
THREE
MISSILES**

**THE SA-2
THREAT
REQUIRED
NEW ECM
EQUIPMENT**

**JACK
RESUMED
OVERFLIGHT
MISSIONS ON
OCTOBER 31,
1964, AFTER
THE FIRST
CHICOM
ATOMIC
BOMB HAD
BEEN TESTED
ON OCTOBER
16**

of the missile was four seconds. The ECM equipment became operational just before Terry Lee flew his seventh overflight mission.

On July 7, 1964, Terry took-off from Cubi Point in a U-2G, a carrier landing model, with the arresting hook removed. Around 8:30 AM the command post in Taoyuan received Terry's Birdwatcher signal. The aircraft had reached altitude and the equipment on board was working. He was ready to penetrate the bamboo curtain. Terry's mission plan was to fly into the mainland at the coast between Hong Kong and Hainan, then zigzag over Kwangtung and Fukien provinces and fly back to Cubi Point.

At the same time, the crew at Taoyuan was busy launching another overflight mission. This was Johnny Wang's first mission. It was a short mission of only five hours. He planned to climb to the northeast until reaching altitude, then turn left to arrive at Shanghai about an hour later. The planned course covered targets in Nanking, Wuhan, Hangchow, Shangjao (where Robin Yeh had crashed) and Foochow. The estimated time for leaving the mainland was a few minutes past noon.

On the other side of the Taiwan Straits, the ChiCom's air defense was very busy. Another ROC-AF RF-101 reconnaissance aircraft planned to take photos over the coast between Quemoy and Swatow at about the same time. The SA-2 battalion located in Changchow (about fifty miles west of Quemoy) was recently transferred from Inner Mongolia. The missiles, launchers, fire-control radar, missile guidance system, and the power supply equipment had just traveled 1,200 miles over mostly unpaved highway. The ChiCom battery reinstalled them on the newly constructed site and with the new ECM.

Around 11:35 AM the SA-2 battalion detected the RF-101 approaching from the East at low altitude. All four missiles and launchers were ready, but the RF-101 did not come within missile range. They turned off the power. Seven minutes later, they turned on the power again, when they detected Johnny's U-2 at seventy miles north. But Johnny continued his course for a short while and then turned away. Three minutes later, they detected the RF-101 coming back at about sixty-five miles away from the site. It soon turned east toward Tungshan Island and disappeared on their search radar scope. At 12:15 PM, Terry's U-2 was about 100 miles south of the missile site and flew past Swatow leaving the mainland. The SA-2 battery was disappointed to watch all three targets fly near the site without reaching missile range.⁷ A photo taken by Johnny Wang found several MiG-21s on an airfield about fifty miles west of Nanking.⁸

A few minutes later, Terry turned back toward Changchow. The SA-2 battery scrambled to reset all the equipment to operational mode. At 12:36 PM, the command post in Taoyuan suddenly heard Terry's excited voice over the SSB radio reporting that the red light of System 12 was flashing. That

meant the missiles were already on their way. Neither Birdwatcher nor UHF radio received any further signals from that U-2. The ChiComs had fired three missiles. They later found the aircraft wreckage at seven miles west of the site and the pilot was dead in the cockpit. They also reportedly found that the ejection seat had no dynamite cartridge.⁹

U-2s did not have the canopy ejection mechanism at that time. The pilot had to open the canopy manually to egress from the cockpit in an emergency, a difficult operation for a wounded pilot under uncontrollable flying conditions. The pilot should be able to exit the aircraft by using the ejection seat to pierce the canopy plexiglass. A power jettison system was installed in the canopy in 1965—too late for Terry.

Up to that time, SA-2s had shot down three U-2s over mainland China and there were only a few successful missions between the shootdowns. After Robin's disaster only three missions flew over mainland China in the next eight months. We could not photograph the nuclear ICBM development area. Missions were planned to avoid flying near the suspected SA-2 sites, but the fast and secret relocation of the ChiCom's surface to air missile batteries could still ambush the U-2s. The radar-warning receiver, System 12, on board was losing its effectiveness. The SA-2 threat required new ECM equipment. System 13 arrived in September 1964. A deceptive jammer, System 13 could cause the target displayed on the radarscope to appear to be a few miles off the correct position. But the system was bulky and heavy and it took two pods mounted on the slipper tank stations to carry it—one for the jammer and one for the power supply. Their extra drag and weight penalized both the maximum altitude and the range of the U-2. The mission to reach the atomic weapon development area became even more marginal. A base in Thailand became the new launch airfield for the overflight missions.

Not long after Terry's tragedy, Liyi "Jack" Chang and Chenwen "Pete" Wang reported to the squadron after completed their U-2A training at Davis-Monthan AFB. They arrived at Tahkli Royal Thai Air Force Base for operational training in the U-2C and F models. Jack resumed overflight missions on October 31, 1964, after the first ChiCom atomic bomb had been tested on October 16.

Jack left Tahkli at 8:30 that morning. He flew past Kunming toward Lanchow, then covered many targets on the way back to Taoyuan. The surprised ChiComs could send only a few MiGs to intercept the U-2, until Jack almost left the mainland. From then on, the 35th squadron launched several missions from either Tahkli or Taoyuan and recovered at either of these two bases. All were successful. Mission planning did a good job to avoid running into active missile sites and no SA-2s were launched.

The ChiComs' first atomic explosion was equivalent to the Hiroshima bomb. No intelligence believed that the giant nuclear diffusion plant at

SCIENTISTS SUGGESTED THAT... AN INFRARED CAMERA COULD RECORD THE HEAT AT THE PLANT AT NIGHT AND COMPARE THIS WITH RECORDS COLLECTED FROM OTHER PLANTS

Lanchow or the even larger new plant at Paotow had only that capability. What was the process they were using to produce high yield nuclear weapons? The nuclear scientists suggested that the heat generated by these plants revealed some clues. An infrared camera could record the heat at the plant at night and compare this with records collected from other plants. An infrared camera arrived at Taoyuan in November 1964. The Black Cats were ready to undertake the night missions to live up to their namesake's habit of sneaking in at night.

Johnny was the first one to execute a night mission. Unfortunately, his mission aborted due to an electrical failure that knocked out all his cockpit lights. He had to fly back by flashlight. Jack made the second attempt but returned because the camera did not work. Johnny attempted again on November 27. This time he reached about thirty miles away from the plant at Lanchow. From thirty miles away, he was amazed to see the brightness of the lights over the plant. Suddenly, System 12 warned him with its red light flashing and the warning beeps in the headset. The CRT scope of System 12 showed two strobes. One pointed to the site in front, the other one pointed right that showed System 13 was working on jamming the tracking radar of SA-2. He immediately turned the aircraft away from the site. A few seconds later, multiple brilliant missile flames blinded him. The ChiComs must have fired three missiles. The autopilot had helped him while he was recovering from the temporary blindness. While the mission was not totally successful, the detachment rejoiced because System 13 had proven its usefulness.

Pete Wang completed his operational training and was ready to join the other qualified pilots. He flew his first mission on December 9 over the northeast provinces to photograph the MiG manufacturing industry. With the protection of System 13, the operation of 35th squadron proceeded smoothly.

Pilot training was not going well at Davis-Monthan AFB. Shihli "Steve" Sheng bailed out from a U-2 on December 19. On the way to reach the departure point after taking off, he flew into a thunderstorm. The severe turbulence disoriented him and he could not control the aircraft. He returned to his original outfit to fly the F-104. The other trained pilot, Tseshi "Charlie" Wu completed his training. Charlie reported to duty in the 35th squadron at the end of the year.

Night missions continued. The next mission launched from Kunsan, South Korea aborted due to System 13 failure. Johnny flew the next mission on January 9, 1965, from Taoyuan directly toward Lanchow and back. To the detachment's surprise, this mission did not encounter any opposition. It was probably because the ChiComs had moved the SA-2 battalion to another site. They must have figured that the U-2 would never come back to the same site. The mission was perfect. The infrared camera recorded the intelligence needed for understanding the technology utilized in that plant.

The weather forecast over that part of mainland China was good for the next few days. Jack flew the next night mission from Taoyuan to Paotow. Taking off at 6:30 PM, on January 10, he flew past Hangchow, Shanghai, and Tsingtao, then turned left toward Paotow and reached Tsingtao about two hours later. The Birdwatcher reception at the command post was poor and was finally lost. The cause was probably due to the inappropriate SSB frequency selected for that distance and time of day. Around 9:20 PM the ROC COMINT station lost the U-2 position information that they received from intercepting the communication of the ChiCom air defense system. The people at the command post anxiously waited for contact with Jack. The next day the ChiComs broadcast that another U-2 was shot down.

According to the ChiCom's report published many years later,¹⁰ the SA-2 battery used an advanced model of ECM against the System 12 on Jack's aircraft. But why didn't System 13 work? After the pilot switched it on, System 13 should operate automatically to deceive the missile guidance system. Jack had tested this system before he coasted into the target. The ChiComs probably changed the pulse repetition frequency of the tracking radar to be outside the range that System 13 could detect. Under that condition, System 13 would not transmit echoes. The new System 13A corrected this shortcoming.

Jack ejected from the cockpit, while the missile exploded nearby with a blinding flash. Missile fragments had pierced his right shoulder, causing excruciating pain. He could not tell how high he was in the dark night. Fortunately, his parachute automatically inflated in the air. Both ankles were severely sprained when he hit the frozen ground. The pressure suits worn by U-2 pilots at that time were very tight and had room for only one layer of underwear, which could not protect the pilot under subzero temperatures. He wrapped himself in the parachute canopy and stayed there until daybreak, and then he saw a few yurts [circular huts] over the horizon. He crawled for a couple of hours on the snow to the nearest yurt to seek help. The owner of the yurt happened to be an official of the local Communist Party. From that time on, his fate was the same as that of Robin Yeh.

In searching the aircraft wreckage, the ChiComs found a black box intact in the right slipper tank with a small red dynamite package. They disarmed the detonator and took the box out for further investigation. The missile fragments probably cut the circuit wire of the System 13 destruction device, so it did not matter whether Jack had the time to switch on the circuit or not before he left the aircraft. The ChiComs later realized the black box was a radar jammer and developed ECCM equipment.¹¹

In the meantime, the Vietnam War escalated after the U.S. Senate passed the Gulf of Tonkin Resolution on August 7, 1964. North Vietnamese troops infiltrated into South Vietnam to help the Vietcong, and the USSR and PRC sent supplies to

THE CHICOMS FOUND A BLACK BOX INTACT IN THE RIGHT SLIPPER TANK

THE CHICOMS LATER REALIZED THE BLACK BOX WAS A RADAR JAMMER

THE 35TH SQUADRON FLEW OVER NORTH VIETNAM AND THE SOUTHWEST BORDER OF THE PRC TO MONITOR THE MILITARY MOVEMENTS IN THE REGION

CHARLIE HAD BROUGHT BACK A PRETTY GOOD PICTURE OF THE SILVER MIG-21 FLYING BENEATH THE U-2. THIS INCIDENT SHOWED THAT THE MIG-21 COULD ZOOM UP TO REACH THE U-2'S CRUISE ALTITUDE

Hanoi. U.S. warplanes began regular bombing raids over North Vietnam in February 1965. The U.S. needed to know whether the PRC was preparing to become involved as they had in the Korean War. The 35th squadron flew over North Vietnam and the southwest border of the PRC to monitor the military movements in the region. We could not afford to await the investigation of Jack's loss and create appropriate counter measures.

On February 19, 1965, Pete Wang flew from Taoyuan via the South China Sea toward Yunnan province. The planned course covered Haiphong and Hanoi in North Vietnam, and the China-Laos-Burma border. He made a proper evasive maneuver when an SA-2 site south of Kunming triggered his radar warning receiver and jammer. The mission ended with a landing at Tahkli AB, Thailand. The detachment moved to Tahkli and dispatched many missions from there to keep the Sino-Vietnam area under surveillance for the following two months.

Charlie Wu completed his operational training and joined the other two qualified pilots to fly missions. While flying south of Kunming on his second mission on March 14, System 13 started jamming, but System 12 showed no indication. He could hardly decide which way to evade. A MiG-21 suddenly zoomed up about 300 feet away from his left wing tip and then dropped down to disappear. Almost at the same time three heat-seeking air-to-air missiles detonated in front of Charlie's aircraft.¹² System 13 was still going active until Charlie turned it off on the way home over Laos. Electrical noise from faulty equipment on board triggered System 13. It triggered just in time to warn Charlie to look around instead of fixing his eyes on the driftsight. Charlie had brought back a pretty good picture of the silver MiG-21 flying beneath the U-2. This incident showed that the MiG-21 could zoom up to reach the U-2's cruise altitude. The MiG-21 engine would flame out at that altitude and the aircraft would not be able to exercise any controllable maneuver. If the U-2 pilot did not take evasive action, he might collide with the MiG-21 or be shot down by air-to-air missiles. The pilots had better watch six o'clock low with the driftsight. If there was a contrail following and suddenly the contrail disappeared, that MiG must be zooming up above the contrail altitude. It was time to take evasive action.

In March 1965, a U-2 with the full-length avionics hump on the fuselage back arrived at Taoyuan with advanced models of the radar warning receivers and radar jammers. System 12B had a three-inch CRT that showed the pilot the location of the fire control radar. System 9B, mounted on the tail of the aircraft, detected air-to-air fire control radar emissions. On the edge of the CRT, there were four lights that indicated in which quadrant of the System 9B was performing the deceptive jamming. System 13A, mounted inside the fuselage, had better performance than the previous version. A new warning receiver, Oscar Sierra (OS), arrived. This equipment detected the

uplinked SA-2 guidance signal. When the red light of OS blinked, the pilot had better maneuver the aircraft drastically, since the missiles might be already on their way.

The SA-2 missiles were difficult to maneuver at very high speed. Proportional navigation based on the motion of the aircraft guided the missile to the predicted collision point. The irregular motion of the aircraft made it difficult to predict the right collision point. An abrupt aircraft maneuver might cause the guidance error to exceed the 120 meters burst radius of the missile's 130-Kg high explosive warhead. This kind of evasive maneuver for a fighter was not difficult to achieve. It took a very skillful pilot to perform this maneuver in the fragile U-2.

The overflight missions resumed at Taoyuan in April. During the following months Jaichung "Terry" Liu, Chingchang "Mickey" Yu and Jenliang "Spike" Chuang joined the team. They started to fly missions in July. Johnny Wang completed his tenth mission and retired from duty in August. He went to Davis-Monthan to train other ROC pilots.

Missions flew over the coastal provinces from the Sino-North Korea border to the Sino-Vietnam border and photographed targets in North Korea, North Vietnam and Laos. No mission flew deep into mainland China because all of the newly installed electronic equipment made the aircraft heavier and bulkier. To maintain the maximum altitude over denied territory, the aircraft had to carry less fuel and the engine had to deliver more power to compensate for the additional drag. The extra weight reduced the maximum range.

On the other hand, there was not much new military development inside the mainland as the cultural revolution spread swiftly all over the PRC in 1965. Chairman Mao's Red Guards disrupted schools to undertake the crusade of weeding out the bourgeois reactionaries. Public meetings disgraced educated professionals, even Communist officials and forced them to leave their jobs to learn Communism in the labor camps. The nuclear weapons development also experienced some delay due to political turmoil. The third Chinese atomic bomb exploded a year after the second one. The interval between the first and the second tests was only seven months.

All U-2 missions seemed successful. Pilots frequently reported at their debriefings that the MiG-21s tried to intercept them without success. The System 9 only alarmed the pilot once over North Korea. The ChiComs had probably removed the fire control radar to reduce the aircraft weight in order to gain maximum ceiling. Ground radar guided the MiG-21s to the interception point. The MiGs zoomed up and tried to shoot down the U-2 with heat-seeking missiles. The U-2 consequently had a heat shield installed at the end of tailpipe, commonly called "Sugar Scoop," to reduce its infrared signature.

Some pilots reported that they received SA-2 radar warning and had taken evasive actions. We suspected that the ChiCom SA-2 inventory was



Smoke trail of an SA-2 fired at a U-2 during RED FLAG exercise in 1966. (Photo courtesy of the author.)

low since there were no missile launches. The USSR had supplied the ChiComs with five SA-2 batteries with sixty-two missiles in November 1958.¹³ After the Sino-Soviet split finally materialized in July 1960, they had no source to replenish the missiles needed to shoot down the RB-57D and the U-2s. There was also the normal attrition during relocation. Although they tried hard to copy the Russian designed missile and radar; the indigenous PRC missile was not available at that time. They probably did not want to waste a missile before they developed electronic counter-countermeasures (ECCM) against System 13.

Although the overflight missions seemed flawless, the training flights were not going well. Four accidents resulting in three pilot fatalities happened within a year. On October 22, 1965 at 9:00 AM Pete Wang left Taoyuan for two-hour proficiency training. He had completed six overflight missions and had many training flights before. This flight should have a routine exercise. Around 10:00 AM the Birdwatcher in the command post suddenly received signals that showed the U-2 experienced excessive G forces. Forty seconds later

all the Birdwatcher signals stopped transmitting. Pete did not report any emergency condition. He did not bail out from the cockpit. People on the northeastern tip of Taiwan and on a nearby boat witnessed an aircraft diving straight into the ocean. ROC Air Force helicopter and navy ships rushed to the site but found only some debris that did not reveal the cause of this accident. The next day, the U.S. Navy sent deep-sea divers with equipment to the site to salvage the aircraft wreckage without any success. The strong deep sea current around Taiwan might have carried the aircraft away.

Four months later, while Charlie Wu was climbing up to cruise altitude on a local training flight, the engine "overheat warning" light brightened. Charlie suspected a fire in the aft fuselage section. He shut down the engine and attempted to make a forced landing. Because of overcast weather over Taoyuan, he glided to CCK AB in central Taiwan that had the longest runway on the island. When he reached the low altitude, his windshield and canopy frosted. It was probably because he had made a fast descent and the humidity over Taiwan was very high. Without the engine providing defrost, it was almost impossible to remove the frost by rubbing with his gloves. Through the limited opening of the frosted windshield, he could only spot a smaller airfield just ten miles east of CCK. He decided to approach this airfield that had a shorter runway. The approach was too high and fast. He crashed into civilian housing near the airfield and died on impact along with several residents. An elementary school in Hsinchu—his birthplace—was later named for him.

A month later another U-2 crashed. This accident happened on a U-2 transition training flight for a new pilot, Huangdi "Andy" Fan, at Davis-Monthan. The aircraft suddenly went into a diving spiral upon reaching 20,000 ft. Andy almost washed out of the program until an investigation disclosed that a flap actuator had malfunctioned at altitude.

On June 21, 1966 Mickey Yu flew a training mission to Okinawa and back. His engine flamed out at cruising altitude. He did an en route descent but failed to restart the engine after reaching 35,000 feet. He intended to make a forced landing on one of the many islands nearby Okinawa. Concluding that the terrain on the island was too rough to land, he ejected. Unfortunately, he was at too low an altitude and his parachute did not inflate. From the wreckage, an investigation found a crack on fuel tubing that had drained out all the fuel on board.

After several years, the ChiComs had finally made improvements on their own surface-to-air missile based on the Russian SA-2. They named it "Red Flag" and tested it successfully in June 1965.¹⁴ Then production followed with the number of surface-to-air batteries deployed gradually increasing. They resumed firing missiles against the U-2. Spike Chuang was the first one to take the challenge.

U-2 with bicycle landing gear down. (Photo courtesy of the author.)



ON MAY 14, 1966, SPIKE LEFT TAOYUAN VIA THE SOUTH CHINA SEA TO CHULAI IN INDOCHINA

THE CHICOMS HAD FIRED EIGHT MISSILES AGAINST HIM

INTELLIGENCE PREDICTED THAT THEY WOULD EXPLODE AN H-BOMB IN THE SUMMER OF 1967. THE TEST SITE WAS LOP NOR

THE ROUND TRIP TO LOP NOR FROM TAHKLI WAS AT THE MAXIMUM RANGE

THE MISSION LASTED ALMOST NINE HOURS

At 7:40 AM on May 14, 1966, Spike left Taoyuan via the South China Sea to Chulai in Indochina. After covering central Vietnam and the southern part of Laos, he reached Chiengmai in northwestern Thailand around 11:20 AM. Then he flew across Burma to cover the targets in Yunnan province of China. When he had covered most targets and passed Kunming heading south, System 12, System 13, and Oscar Sierra flashed. He started to turn right as the strobe of the scope pointed to the left. About three seconds later missiles exceeded his altitude on the left and then disappeared. Ten seconds later, from the driftsight he saw two more missiles ascending through the clouds. He increased his turning rate and the missiles missed him again. Then he turned back to the original direction, flew toward Tahkli AB and landed there. The ChiComs had fired eight missiles against him.¹⁵

About three months later, Spike encountered another missile ambush. On August 24, he flew a mission over Kwangtung province. In the area near Canton along with those warning signals and evasive maneuver, he witnessed a missile passing by on his left about 1,000 feet away.¹⁶ Andy Fan and Hsieh "Billy" Chang completed their training in the spring of 1967. Terry Liu completed his ten missions and was released from combat duty.

In the seven months after the third atomic bomb test, the PRC had conducted two more tests. The development program seemed to be accelerating and intelligence predicted that they would explode an H-bomb in the summer of 1967. The test site was Lop Nor in the Sinkiang desert region. It was impossible for a U-2 to reach there from Taiwan. However, aircraft No. 383, modified to carry extra 100 gallon fuel tanks, arrived at the 35th squadron. Even with the extra fuel, the round trip to Lop Nor from Tahkli was at the maximum range. With all the electronic gear on board, the first part of the mission must maintain the maximum range cruise altitude below 60,000 feet. This was much lower than the maximum altitude cruise.

Late on the night of May 7, Spike left Tahkli and flew across Burma, northeastern India and the Himalayan mountains toward Lop Nor. Upon

reaching the target in the early morning, he dropped a fifteen-foot long capsule over the desert nearby the nuclear test site. When the nose of this capsule pierced the desert surface and embedded itself deep underground, the petals on the tail would open to serve as solar cells and antenna. The capsule would collect the test data and transmit them to a receiving station in Taiwan.¹⁷ After finishing the photo reconnaissance over the nuclear test area, Spike flew directly back and landed at Tahkli. The mission lasted almost nine hours. Spike took the ChiComs by surprise, as they did not detect the U-2 until it reached the test site. The first PRC H-bomb exploded on June 17. The intelligence transmitted by the capsule and received in Taiwan was not totally satisfactory.

Bill Chang piloted a follow-up mission. He took off at 2:36 at night on August 31, 1967, from Tahkli and flew almost the same course as Spike had. This time the aircraft carried a high frequency (HF) transmitter receiver and a trailing antenna besides the normal electronic warfare equipment. Bill lingered in the area where Spike dropped the capsule to tune up the communication between that remote seismic sensor and the station in Taiwan. He stayed there for ten minutes then continued flying his planned course. On the way back, Bill was not as lucky as Spike. The ChiComs surface-to-air missiles ambushed Bill's U-2. With the help of System 13 and a good evasive maneuver, the missile exploded about 2,500 feet from the U-2. His mission lasted nine hours and twenty minutes.¹⁸

Yenchun Chou and Lungpei "Tom" Hwang joined the Black Cats in the summer of 1967. Unfortunately, an SA-2 shot down Tom Hwang over the mainland on his first mission. On September 8, 1967, Tom left Taoyuan at 8:45 AM and turned left toward Chekiang province. Three minutes after he began to coast in, Oscar Sierra started to alarm. He tried an evasive maneuver but failed. Missile fragments killed him in the cockpit. Later the ChiComs claimed that they had used the Red Flag missiles with the newly developed ECCM that overcame the System 13A jammer.¹⁹

As the number of surface-to-air missile sites over the PRC increased significantly, consideration

**ANDY FAN
HAD CARRIED
OUT THE
LAST
OVERFLIGHT
MISSION ON
MARCH 16,
1968. THEN,
U-2 MISSIONS
ONLY FLEW
ALONG THE
COAST OVER
THE HIGH
SEAS**

**THE U-2
COASTAL
PATROL MIS-
SIONS
STOPPED IN
MAY 1974.
...THE 35TH
SQUADRON
DISBANDED,
ENDING THE
FIFTEEN-
YEAR JOINT
RECONNAIS-
SANCE OPER-
ATION**

was given to cancelling the overflight missions. Andy Fan had carried out the last overflight mission on March 16, 1968. Then, U-2 missions only flew along the coast over the high seas. With the long-range oblique photography, the U-2 could still image activities on the ground up to sixty miles inland. An advanced COMINT recorder, System 21, could record twenty-eight voice channels simultaneously versus the three-channel capability of System 3. This SIGINT and COMINT collection system produced additional intelligence. It was a great relief to the pilots, as the missions would no longer have to face the threat of enemy surface-to-air missiles. The reliability of the U-2C was a concern because of its age.

On January 5, 1969, Bill Chang flew from Taoyuan to the East coast of PRC. There was a strong cold front passing through the Taiwan-Okinawa area. The autopilot quit and the air was turbulent. He lost control and called mayday as the structure failed. He bailed out over the Pacific Ocean about 165 nautical miles northeast of Taoyuan. The search and rescue aircraft and boats remained at the accident area for several days, but they found only a few pieces of aircraft. Some fishermen found his remains nearby P'engchua Yu a year later.

The new U-2R arrived at Taoyuan in the spring of 1969. This aircraft was much larger than the previous models and had better performance. Its spacious cockpit could accommodate the full pressure suit that gave pilots better protection at high altitude. The U-2R carried a new infrared warning sensor, System 20, in addition to the normal U-2C electronic warfare equipment. System 20 alerted the pilot that an enemy fighter was in the tail cone area. It gave the pilot time to take evasive action to avoid the fighter zooming up to shoot heat-seeking missiles. The coastal patrol missions continued. Pilots fulfilled their duties, rotated out of the 35th squadron and new pilots joined the squadron. Nine ROC pilots completed their training at Edwards AFB, California, from 1968 to 1973.

One of the new pilots died during a routine proficiency training flight. In the afternoon of November 24, 1970, Chihhsien "Denny" Wang flew back from a two-hour flight and approached to land. He was about to touch down when a side gust suddenly pushed his left wing up and made his right wing tip collide with a runway distance marker. The aircraft drifted into a potato field along the runway. He pushed the throttle to get airborne again. This was similar to the first 35th squadron U-2 accident. It appears that appropriate control did not stop the yawing of this 104-foot long-wing aircraft in the near stall speed region. This caused its left wing to lose lift totally. The aircraft hit the ground and burst into flames.

The accident did not interrupt the operation for long. A new U-2R was soon delivered to the 35th Squadron to replace the one lost. Although the U-2 flew at least twenty miles off the mainland coast, the missions were not completely safe from ChiCom Red Flag missiles. On December 1, 1969,

Tao "Tom" Wang flew past a small island, forty miles off the coast off Chekiang province. Suddenly, all of the RWR and ECM systems on board came on. He made a drastic evasive maneuver. Three missiles exploded about several hundred feet from his right wing.²⁰

Besides the missiles, MiG-21s frequently came up to intercept. A zooming MiG-21 almost collided with Chungli "Johnny" Shen on April 29, 1971. While he was flying over the Yellow Sea near Tsingtao, System 20 detected a heat source from the left. He turned to the left to point his tailpipe away from the pursuing fighter. When the warning light went off, he turned back to his original course. Then the warning came again. This time System 20 showed the heat source was on the right. He started to turn right and heard a loud noise. Almost about the same time, he saw a silver MiG-21 zooming up less than 500 feet from the right wing through his own 73,000-foot altitude and then dropping out of sight. The loud noise might have been the sonic boom when the MiG accelerated to supersonic speed.²¹

President Richard Nixon visited Peking in the last week of February 1972. The U.S. government started to remove its military forces from Taiwan. President Nixon had pledged this to Premier Zhou Enlai during his visit. The U-2 coastal patrol missions stopped in May 1974. Two U-2Rs remained for three months before being flown back to Okinawa by American pilots. The 35th squadron disbanded, ending the fifteen-year joint reconnaissance operation.

During these fifteen years, ROC pilots flew 102 missions that penetrated the bamboo curtain, including overflights over North Korea and Northern Indochina. Surface-to-air missiles shot down five U-2s over mainland China. Three pilots were killed and two were taken prisoner. (American U-2s penetrated Soviet airspace twenty-four times. One aircraft was lost, no one was killed.²²) The U-2 designers emphasized mission success above safety and controllability. Seven other pilots lost their lives in routine training flights and coastal patrol missions.

What had this joint operation accomplished? What did the pilots contribute? The U-2 program provided sufficient intelligence to the Republic of China in Taiwan to refine the strategy of recovering the lost mainland. The best time to invade the mainland was 1963. PRC had not restored their economy after the great famine of 1961 and the Sino-Russia split in 1960. Their capability to produce a nuclear weapon was yet to be seen. However, military activity against PRC required the approval of the United States under the U.S.-ROC Mutual Defense Treaty signed in December 1954. The United States did not support military activity against the mainland or even the proposed airdrop of small scale special forces to establish anti-communist bases inside the mainland. Finally, President Chiang Kai-Shek sent his son, General Chiang Ching-Kuo to Washington, D.C. to solicit concurrence. He met with President Kennedy in

THE U-2 ONLY PROVIDED EARLY WARNING TO ROC ABOUT ANY INTENTION OF THE CHICOMS TO INVADE TAIWAN

THE PEOPLE'S REPUBLIC OF CHINA MAY HAVE BEEN THE MAJOR BENEFICIARY OF THIS JOINT RECONNAISSANCE OPERATION

Republic of China U-2 Pilots					
Name	First Mission	Overflight Missions	Coastal Missions	Total Mission Time Over Denied Area	Status
Yoahua Chih					Killed in accident, 1961
Huai Chen	1-13-62	4		18:35	Killed in combat, 1962
Shihchu "Gimo" Yang	2-23-62	8		53:14	
Hsichun Mike Hua	3-17-62	10		76:33	
Taiyu "Tiger" Wang	3-26-62	9		66:58	
Nanping "Terry" Lee	8-24-63	7		42:56	Killed in combat, 1964
Changti "Robin" Yeh	8-30-63	3		15:38	Captured in combat, 1963
Shichuen "Johnny" Wang	7-7-64	10		59:17	
Tehpei "Sonny" Liang					Killed in accident, 1964
Liyi "Jack" Chang	10-31-64	5		24:17	Captured in combat, 1965
Chenwen "Pete" Wang	12-9-64	6		40:23	Killed in accident, 1965
Tseshi "Charlie" Wu	2-24-65	6		28:55	Killed in accident, 1966
Chingchang "Mickey" Yu	7-20-65	6		29:05	Killed in accident, 1966
Jenliang "Spike" Chuang	7-21-65	8	1	46:18	
Jaichuang "Terry" Liu	7-31-65	10		57:00	
Huangdi "Andy" Fan	3-28-67	6	5	31:05	
Hsieh "Billy" Chang	5-16-67	2	6	14:06	Killed in mission, 1969
Yenchun Chou	8-10-67	1	1	4:10	
Lungpei "Tom" Hwang	9-8-67	1			Killed in combat, 1967
Chihhsien "Denny" Hwang	10-20-68		7		Killed in accident, 1970
Paowei "David" Lee	12-19-68		7		
Tao "Tom" Wang	4-8-69		19		
Chungli "Johnny" Shen	5-28-69		18		
Chu Chien	5-26-71		23		
Sungchou Chiu	4-19-72		19		
Chen Wei	1-31-73		9		
Chichiang Yee	2-12-74		2		
Shenghsiung "Mory" Tsai	4-11-74		1		
Total Missions		102	118		

the White House on September 11, 1963, but no agreement was reached. From that meeting on, the possibility of recovering the mainland was continuously wearing thin. The U-2 only provided early warning to ROC about any intention of the ChiComs to invade Taiwan or the offshore islands.

For the United States, Detachment H provided the precise locations of the targets in the Far East area for its global defense strategy and monitored the nuclear weapon development in the PRC. The intelligence collected on these missions was obviously essential to the safety of the U.S. forces fighting in Vietnam and stationed in South Korea. Detachment H provided real tests of the airborne electronic warfare equipment, including the radar warning receiver, the radar jammer, the infrared detector, and the various wide band signal recorders in hostile territory.

On the other hand, the People's Republic of China may have been the major beneficiary of this joint reconnaissance operation. After the Korean War ceasefire, the ChiComs concentrated their efforts on controlling the people on the mainland. They issued ration tickets for food and clothing. They required travel permits for people to visit other cities. They censored private communication. The Communist party controlled the media. Radio and newspapers reported only Communist indoctrination.

Their security services were very successful in eliminating any kind of infiltration by agents.

No one in the free world knew how the PRC shot down the ROC RB-57D near Peking in October 1959, until they officially released the details in 1989,²³ that attributed it to an SA-2. If the United States had suspected that a Russian built surface-to-air missile shot down that aircraft, Francis Powers would probably not have penetrated USSR air space in May 1960. Even three years later, Huai Chen would have had System 12 on board to save his life. Robin Yeh and Jack Chang lived in prison and then were released to stay on the mainland for almost twenty years. They did not know of each other's existence until the ChiComs decided to let them leave PRC as propaganda after the U.S.-PRC Joint Communiqué signed on August 17, 1982.

It was impossible to collect intelligence in the PRC through traditional espionage methods. Without the U-2's electronic intelligence, Dr. Henry A. Kissinger would not have known before his second visit to Peking in October 1971, that Marshall Lin Piao had died after the failure of an attempted coup.²⁴ Lin Piao was the PRC defense minister and the officially designated heir of Chairman Mao. Without the U-2 overflight intelligence President



THE PILOTS OF THE 35TH SQUADRON ENDURED LONG, HARD HOURS, SQUEEZED INTO A SMALL COCKPIT

Nixon might not have been able to implement his strategy of rapprochement toward the PRC.²⁵ Subsequently, President Nixon visited Peking before extending them U.S. recognition.

The pilots of the 35th squadron did not expect to contribute towards easing the tension of the Cold War in realizing the depth of conflict between two most influential countries of the Communist

block. They endured long, hard hours, squeezed into a small cockpit, facing the danger of enemy missiles, and their own aircraft malfunctioning deep inside the enemy territory. They were just patriotically executing the missions for the Republic of China. Nevertheless, they had performed the most courageous operations in U-2 history. ■

NOTES

1. "The CIA and the U-2 Program, 1954-1974". Washington, D.C.: Center for the Study of Intelligence, 1998.
2. *Ibid.*
3. *China Today: Air Force* [Dangdai Zhongguo Kongjun]. Beijing: Aviation Industry Press, 1989.
4. *Chinese Air Force in Action II*, Taipei, 1995. [ISBN:957-8628-11-0]
5. "Secret of Yesterday [Tso Tien Ti Pi Mi], in commemoration of the 30th anniversary of the Air Force Surface-to-Air Battalions", PRC Air Force magazine, September 6, 1988.
6. *Ibid.*
7. *Ibid.*
8. "History of the Special Operations", ROC Air Force Archive, Taiwan.
9. "Secret of Yesterday [Tso Tien Ti Pi Mi], in commemoration of the 30th anniversary of the Air Force Surface-to-Air Battalions", PRC Air Force magazine, September 6, 1988.
10. *Ibid.*
11. *Ibid.*
12. "History of the Special Operations", ROC Air Force Archive, Taiwan.
13. "Secret of Yesterday [Tso Tien Ti Pi Mi], in commemoration of the 30th anniversary of the Air Force

- Surface-to-Air Battalions", PRC Air Force magazine, September 6, 1988.
14. *Ibid.*
15. "History of the Special Operations", ROC Air Force Archive, Taiwan.
16. *Ibid.*
17. *Ibid.*
18. *Ibid.*
19. "Secret of Yesterday [Tso Tien Ti Pi Mi], in commemoration of the 30th anniversary of the Air Force Surface-to-Air Battalions", PRC Air Force magazine, September 6, 1988.
20. "History of the Special Operations", ROC Air Force Archive, Taiwan.
21. *Chinese Air Force in Action II*, Taipei, 1995. [ISBN:957-8628-11-0]
22. "The U-2: A Revolution in Intelligence" Washington, D.C.: National Defense University conference, September 17, 1998.
23. *China Today: Air Force* [Dangdai Zhongguo Kongjun]. Beijing: Aviation Industry Press, 1989.
24. Chris Pocock. *Dragon Lady*. London: Airlife Publishing Ltd., 1989.
25. Henry A. Kissinger. *White House Years*. Boston: Little, Brown & Co., 1979.

Sabre Pilot Pickup: Unconventional Contributions to Air Superiority in Korea





Forrest L. Marion

(Overleaf) F-86Es of the 51st FIW in 1952. (AFHRA Photo)

(Near right) One of two new H-19s delivered to the 3d ARS in February 1952. (AFHRA Photo)

(Far right) An H-5 equipped with floats. The H-5s performed short-range rescues and medical evacuations in Korea. (AFHRA Photo)

USAF AIRCRAFT THAT PICKED UP DOWNED FIGHTER PILOTS ... CONTRIBUTED IN THREE WAYS TO THE AIR SUPERIORITY MISSION IN KOREA

THEY RECOVERED KEY COMPONENTS OF MIG AIRCRAFT ... PILOTS COULD "FLY AND FIGHT" AGAIN ... [AND] THEY IMPROVED THE MORALE OF EVERY FIGHTER PILOT



In an interview with the air component commander of NATO's "air effort" against Serbia in 1999, U.S. Air Force Lt. Gen. Michael C. Short described the tense hours on the war's fourth night.¹ During those hours, the fate of a downed American F-117 pilot hung in the balance and, perhaps with it, the support of a somewhat divided American populace. General Short stated, "I remember a senior officer from another nation who had sat with us most of that night when it was over saying to me, 'I can't tell you how impressed I was with what you were willing to do to get that pilot back, and the clear message being sent that this happened to be an American pilot, but if it had been a Spanish or a Canadian or Italian or German or a Frenchman or a Brit, it wouldn't have mattered, that you were gonna spend everything you had to go in and get him. And me as a member of another NATO air force, I'm impressed by that.' And I remember saying to him: 'It has always been that way in my air force...'" And that was a legacy of Vietnam and a legacy of the Gulf War, that we will go and get a fellow [airman] if it's at all possible." Although the general's remarks were quite insightful, he was wrong on one point: the legacy dated not from Vietnam, but from Korea.²

Much has been written on air superiority during the Korean War, focused mainly on the aerial combat between F-86 and MiG-15. Some attention has been devoted to air-sea rescue, but one gap in the historiography of the "forgotten war" has been the contributions made to U.S./ UN air superiority by the USAF aircraft that picked up downed fighter pilots. Sikorsky-built helicopters, mainly the newer H-19 but to some degree the older, less-capable H-5, and the amphibious Grumman SA-16, contributed in three ways to the air superiority mission in Korea. First, they recovered key components of MiG aircraft, increasing

U.S./U.N. technical knowledge of the enemy's new and formidable jet fighter. Second, by returning Sabre pilots from behind enemy lines or the hostile waters of the Yellow Sea, the pilots could "fly and fight" again. Third, they improved the morale of every fighter pilot who realized that if the unthinkable happened to him, the USAF would "spend everything...to go in and get him."

In 1951, within nine months of the MiG-15's appearance in Korean skies, two U.S./U.N. recovery efforts led to increased technical knowledge of the advanced enemy fighter. By March 10, 1951, Lt. Gen. Earle E. Partridge, Fifth Air Force Commander, had decided to make the salvage of a crashed MiG-15 a top priority. Years later he recalled:

*General Ben Chidlaw, head of the Air Materiel Command...told me that we really didn't have any intelligence on the MiG-15, on the physical structure of it and what kind of guns it had and what the ammunition was like, and he said, "Why don't you get one?" And I said, "Why didn't you tell me your Foreign Intelligence Section needed one?"*³

Partridge delegated the task to an enigmatic intelligence genius named Donald Nichols, whom the general described as "an incredible man," one who "could do almost anything," and a "one-man war." Nichols was an Air Force intelligence officer in charge of Special Activities Unit Number One. Three weeks later, Nichols began a training program including parachute jumping, salvaging of aircraft parts, and concealment in enemy territory. Operational plans were still incomplete on April 13, when an F-80 Shooting Star pilot of the 51st Fighter-Interceptor Wing reported the location of a crashed enemy swept-wing fighter south of Sinanju, North Korea. Word reached Fifth Air

Forrest L. Marion graduated from the Virginia Military Institute with a BS degree in civil engineering. He earned an MA in history from the University of Alabama and a doctorate in American history from the University of Tennessee. Dr. Marion served twelve years on active duty in the United States Air Force, seven of them as a helicopter pilot. Currently, he is assigned both as a civilian historian and a reservist with the Air Force Historical Research Agency at Maxwell AFB, Alabama.

Date	F-86 Pilot	Unit	Rescue Aircraft	Rescue Location	F-86 Operating Area
13 Sep 51	Pilot Unk	334 FIS	SA16	Yellow Sea	Mig Alley
06 Oct 51	Lt Bill N. Garrett	4 FIG	SA16	Chongchon R.	Mig Alley
13 Dec 51	Capt Ken. D. Chandler	336 FIS	Helo	Vic. Chodo	Mig Alley
18 Dec 51	Lt George M. Pistole	25 FIS	SA16	No. of Chodo	Mig Alley
01 Apr 52	Lt John E. Dews, Jr.	336 FIS	H19	Chodo Island	Mig Alley
02 Apr 52	Lt Joe L. Cannon	25 FIS	H19	Vic. Chodo	Mig Alley
15 May 52	Lt Harry L. Shumate	25 FIS	Unk	Unk	Mig Alley
18 May 52	Capt Herbert E. Sharp	4 FIG	Helo	Mouth of Yalu R.	Mig Alley
07 Jun 52	Lt Gilbert E. Mann	25 FIS	H19	Vic. Chodo	Vic. Pyongyang
07 Jun 52	Lt Rich'd S. Drezen, Jr.	25 FIS	SA16/H5	Yellow Sea	Vic. Pyongyang
08 Jun 52	Lt Robert Chesney	334 FIS	Unk	Vic. Chodo	Mig Alley
04 Jul 52	Capt Clifford D. Jolley	335 FIS	H5	Vic. Chodo	Mig Alley
12 Jul 52	Capt Patrick M. Ellis	16 FIS	H19	No. of Chodo	Mig Alley
08 Aug 52	Lt James I. Bonini	16 FIS	SA16	Vic. Chodo	Mig Alley
20 Aug 52	Lt Norman Schmidt	334 FIS	SA16/H19	Yellow Sea	Mig Alley
04 Sep 52	Lt Ira M. Porter	335 FIS	SA16	Yellow Sea	Mig Alley
04 Sep 52	Lt Laverne G. Stange	25 FIS	H19	Yellow Sea	Mig Alley
15 Sep 52	Lt Arthur J. Cuddy	336 FIS	SA16	No. of Chodo	Mig Alley
28 Sep 52	Maj Alex J. Gillis	335 FIS	H19	Unk	Mig Alley
03 Oct 52	Maj Frederick C. Blesse	334 FIS	SA16	Yellow Sea	Mig Alley
11 Oct 52	Lt John E. Fagan	336 FIS	H19	NK mud flats	Mig Alley
16 Oct 52	Lt Col Carl W. Stewart	51FIG	Unk	Vic. Chodo	Mig Alley
21 Nov 52	Maj Vernon J. Lyle	25 FIS	H19	Unk	Mig Alley
21 Nov 52	Lt P.D. Blakely	25 FIS	H19	Unk	Mig Alley
22 Nov 52	Lt Edmund G. Hepner	16 FIS	H19	Vic. Chodo	Mig Alley
28 Dec 52	Lt John J. Breen	16 FIS	SA16	No. of Chodo	Mig Alley
25 Jan 53	Capt Murray Winslow	335 FIS	H19	Vic. Chodo	Mig Alley
31 Mar 53	Lt Frank D. Frazier	336 FIS	Unk	Vic. Chodo	Mig Alley
12 Apr 53	Capt Jos. C. McConnell	39 FIS	H19	Yellow Sea	Mig Alley
12 Apr 53	Lt Norman E. Green	335 FIS	SA16	Yellow Sea	Mig Alley
16 Apr 53	Lt Robert E. Crackel	8 FBG	Helo	Chodo Island	Mig Alley
30 Apr 53	Capt Lonnie R. Moore	335 FIS	H19	No. of Chodo	Mig Alley
16 May 53	Pilot Unk	Unk	H19	No. of Chodo	Mig Alley
17 May 53	Lt Dorris	12 FBS	H19	Vic. Chodo	Chinnampo, NK
17 May 53	Pilot Unk	4 FIG	H19	Vic. Chodo	Unk
27 May 53	Lt Douglas G. Brenner	25 FIS	SA16	Yellow Sea	Mig Alley
05 Jun 53	Flt Lt James A. Ryan	16 FIS	SA16	Yellow Sea	Mig Alley
15 Jun 53	Lt Richard W. Frailey	334 FIS	SA16	Mouth of Yalu R.	Mig Alley
16 Jun 53	Pilot Unk	8 FBG	Helo(?)	Vic. Chorwon	North of MLR
29 Jun 53	Maj Flamm D. Harper	18 FBG	H19	Haeju Peninsula	Haeju Peninsula
11 Jul 53	Pilot Unk	8 FBG	Helo	Unk	North of MLR

Note 1: "Chodo Island" indicates pilot landed on the ground at Chodo; "No. of Chodo" indicates a water landing north of Chodo; "Vic. Chodo" indicates vicinity of Chodo (either on ground or nearby waters); "MLR" indicates the main line of resistance (i.e., the front); "Unk" indicates data unknown.

Note 2: Some primary sources are in disagreement as to whether particular pilots wore the rank of second lieutenant or first lieutenant at a given time. For the sake of simplicity, I elected to refer to all USAF lieutenants as "Lt" in the table.

Note 3: Table based on various sources, especially the following: F-86 unit histories (AFHRA); 3rd Air Rescue Squadron/Group histories (AFHRA); Headquarters Far East Air Forces Daily Combat Operations Reports (AFHRA, between 12 Apr 52 and 27 Jul 53); information on F-86 losses compiled by Ron Maynard, Defense POW/Missing Personnel Office, Arlington, Va.; Air Force Times; various personal communications with former F-86 pilots.

THE PARTY PHOTOGRAPHED AND EXTRACTED VITAL COMPONENTS OF THE MiG

Force Headquarters the next morning. After several unsuccessful photo reconnaissance flights to locate the crashed fighter, success came a day later and photo interpretation confirmed the aircraft as a MiG-15. The jet appeared to be unguarded and in relatively good condition, making it an attractive target. The salvage mission was on.⁴

Early on April 17, Mr. Nichols and two Koreans departed Taegu aboard a transport aircraft. Arriving at Seoul, they were joined by four more Koreans. The party soon departed in the 3d Air Rescue Squadron's newly arrived YH-19 helicopter for Paengnyong-do, a friendly-controlled island in the Yellow Sea just below the 38th parallel. After refueling, the helicopter departed and flew north, landing in a barley field two hundred meters from the crashed MiG. Friendly fighters provided cover en route and F-51 Mustangs strafed the area just prior to the helicopter landing. The H-19 pilots

remained in the helicopter, while the salvage party proceeded to the MiG. Overhead, friendly fighters maintained their protective cover. Over the next thirty minutes, the party photographed and extracted vital components of the MiG, including turbine blade, fuselage, and ammunition samples. Using hand grenades, they blew apart the aircraft and obtained the engine exhaust pipe, exhaust pipe cover, and combustion chamber and carried them to the waiting helicopter. Nichols dragged the horizontal stabilizer to the helicopter. By 1700 hours, the H-19 was airborne for Cho-do, an island located less than four miles from the North Korean mainland, forty miles north of the 38th parallel. On the way out of North Korea, near Sinanju, the helicopter came under enemy antiaircraft fire, taking one hit in the blade. Refueling at Cho-do, the H-19 continued south to Paengnyong-do where the salvage party transferred to a 3d Air Rescue Squadron SA-16 amphibian, that flew them to Seoul. From there, they boarded a C-47 for Taegu, arriving that night. Soon, the salvaged parts were en route to Wright-Patterson AFB, Ohio, for analysis.⁵

Note that this was a "special operation" mission conducted by a team of special operators using Air Rescue aircraft and aircrews. Three months later, another MiG recovery operation engineered by Nichols, this one near Cho-do, salvaged even more components than had the first one. In September 1951, the first issue of the *Fifth Air Force Intelligence Summary* featured a comparison of F-86 and MiG-15 characteristics, an analysis based upon the second MiG recovery operation. Thus, the newly acquired technical knowledge of the MiG-15 already was beginning to reach the F-86 pilots who were flying counter air patrols in "MiG Alley," increasing their understanding of the enemy's capabilities and vulnerabilities.⁶

Rescue and special operations aircraft also contributed to air superiority by picking up downed F-86 pilots from behind enemy lines or out of the Yellow Sea. In one of the earliest Korean War pickups of a fighter pilot from behind enemy lines, on September 4, 1950, an H-5 helicopter belonging to the 3d Air Rescue Squadron picked up Capt. Robert E. Wayne, 35th Fighter-Bomber Squadron, who had bailed out of his F-80 Shooting Star. Three months after Wayne's rescue, Sabres of the 4th Fighter-Interceptor Wing entered combat in Korea. Surprisingly, the earliest verifiable "behind the lines or northern Yellow Sea" rescue took place some ten months later, on September 13, 1951, when a 3d Air Rescue Squadron SA-16 picked up, from the Yellow Sea, a pilot in the 334th Fighter-Interceptor Squadron. From then until the armistice in July 1953, forty-one Sabre pilots were returned to "fly and fight" again. Thirty-seven of these pickups took place in the last sixteen months of the war.⁷

The pickup of downed personnel by helicopter was still a new phenomenon early in the war. Lt. Gen. James D. Hughes, USAF(Ret.), who flew F-80s in Korea in the summer of 1950, recalled that pilots

(Near right) Lt. James I. Bonini and his F-86 in Korea, 1952. On August 8, 1952, Bonini was rescued by an SA-16 from the Yellow Sea in one minute and 10 seconds, one of the fastest water pickups on record. (Photo courtesy of J.I. Bonini)

(Far right) Capt Joseph C. McConnell, Jr., was rescued on April 12, 1953 by a "Special Operations" H-19 helicopter. After his rescue, Capt. McConnell went on to down 8 more MiGs, and became the war's leading ace with 16 aerial victories. (AFHRA Photo)



THE PRACTICE OF PICKING UP DOWNED AIRMEN BECAME A STANDARD PROCEDURE FOR THE U.S. AIR FORCE

PERHAPS ONLY HALF OF ALL PILOTS WHO DECIDED TO ABANDON THEIR AIRCRAFT EVER HAD A REAL CHANCE FOR RESCUE ... SABRE PILOTS ENJOYED A CONSIDERABLY BETTER CHANCE OF RESCUE

in his unit received a blood chit, gold coins, and a "pointie-talkie—that was it. If a pilot went down behind enemy lines, he "expected to have to walk out." The concept of rescue was so new that in March 1951, during the rescue of an F-80 pilot by an H-5 helicopter off the coast of Inchon, a fellow F-80 pilot in the vicinity who was in contact with the helicopter made the following radio call to his distressed flight mate: "Frank, this is Steve. They got an air-rescue aircraft coming out to pick you up, ol' buddy. It's a helicopter, believe it or not! Yeah, a helicopter...beats me where they got it, but they got it. Just hang in there, man." In fact, the H-5 did rescue the downed pilot and flew him to an Army hospital near Seoul.⁸

The pickup of so many Sabre pilots illustrates that during the Korean War the practice of picking up downed airmen became a standard procedure for the U.S. Air Force. During World War II, when air-sea rescue was in its infancy, the chances for a downed airman to be rescued were slim, regardless of the type of rescue vehicle used. But in Korea, downed USAF airmen had roughly a one-in-ten chance of being rescued. While ten percent may not seem impressive, one must consider that many pilots never had a real opportunity for rescue. Some failed to get out of their aircraft, others perished at some point between getting out and hitting the ground or water, some were captured almost immediately upon landing, and still others died from exposure to the elements or drowned before rescuers could reach them. Taking these factors into consideration, a rough estimate is that perhaps only half of all pilots who decided to abandon their aircraft ever had a real chance for rescue.⁹

In spite of such obstacles, Sabre pilots enjoyed a considerably better chance of rescue than one-in-ten, probably about one-in-four, for which there were several reasons. First, because they operated

at altitudes usually above 30,000 feet, if the aircraft was hit or sustained mechanical problems, the pilot could use his altitude—as well as an excellent glide ratio—to make his way toward friendly territory, normally toward the designated "bail out" area near Cho-do, a northern island used by friendly radar, Air Rescue, and "special ops" elements. In one case in August 1952, Lt. James I. Bonini, 16th Fighter-Interceptor Squadron, was picked up by an SA-16 after having been in the water for only one minute and ten seconds, one of the war's quickest rescues from the water. The lieutenant had experienced engine flameout while operating at 40,000 feet near the Yalu and had glided for approximately 110 miles to Cho-do before leaving his jet. Although Bonini glided farther than most Sabre pilots in similar straits, others followed the same general procedure, which found its way into Maj. Frederick C. Blesse's 1955 USAF Fighter Weapons School tactics manual.¹⁰

Second, the geography of the Korean peninsula favored the Sabre pilot. Most aerial engagements took place north of the Chongchon River, if not always between that river and the Yalu. Many engagements took place not far from the coast, which meant that, if a Sabre pilot needed to prepare to eject but still had a flyable jet, the flight toward Cho-do was only one-half the distance to home base. Furthermore, it was almost entirely over water. Those were important considerations, suggested by the fact that of the forty-one Sabre pilots included in this study, fourteen were rescued from the vicinity of Cho-do (several pilots landed on the island but most in the waters nearby), ten others from waters (including coastal mudflats) somewhere north of Cho-do, and ten from unknown parts of the Yellow Sea but presumably north of the 38th parallel. Thus, at least thirty-four of forty-one Sabre pilots rescued from north of the

Maj. Joel Grimshaw and fellow Rescue Control Center officers. Some rescue missions required very detailed planning. (Photo courtesy of Judith Grimshaw Ginder)

BETWEEN JUNE 7 AND SEPTEMBER 15, 1952, 3D AIR RESCUE SQUADRON AIRCRAFT PERFORMED TEN CONSECUTIVE SABRE PILOT PICK-UPS FROM THE YELLOW SEA AREA



THE SA-16 ENJOYED SPEED AND RANGE ADVANTAGES OVER THE HELICOPTERS

38th parallel were picked up from the general area of the Yellow Sea. During one period, between June 7 and September 15, 1952, 3d Air Rescue Squadron aircraft performed ten consecutive Sabre pilot pickups from the Yellow Sea area, four of them from the vicinity of Cho-do. On September 4, Rescue aircraft pulled two Sabre pilots from the water, Lts. Ira M. Porter and Laverne G. Stange. That day Stange had downed one MiG and Porter two. Porter destroyed another MiG in December.¹¹

Two other factors contributed to the relatively high rate of rescue for Sabre pilots—Allied naval supremacy in the Yellow Sea, and the fact that MiG pilots generally remained over the Northwestern portion of the peninsula, avoiding the Yellow Sea. Former North Korean MiG-15 pilot Kenneth H. Rowe, (“Lt. No Kum-Sok” prior to his defection in 1953) recalled this reluctance was due to the enemy’s lack of any rescue capability for downed MiG pilots.¹² Thus, once a Sabre pilot was “feet wet,” his chances were very good for an undisturbed flight as far south as he could manage, and if he could reach the water safely he was spared from any anxiety about the enemy’s navy. Thus, the Sabre’s high operating altitude, favorable Korean geography, friendly naval supremacy, and MiG operating limitations combined to offer F-86 pilots considerably better odds of returning to “fly and fight” another day than without such advantages. Of course, even these advantages would not have amounted to much if Air Rescue and special operations forces had not been available and willing to go well north in many cases to perform the actual pickups.

Although daring rescues of pilots from behind enemy lines or the Yellow Sea became almost commonplace in Korea, three particular F-86 pilot rescues at different times in the war illustrate the basic pickup modes accounting for almost all those

rescues performed by aircraft: by SA-16 in the Yellow Sea; by H-19 in the Yellow Sea; and by helicopter, H-5 or H-19, from the North Korean mainland. In October 1951, in the earliest known “behind the lines” rescue of a Sabre pilot whose identity has been determined, an SA-16 piloted by Capt. Robert C. Mason landed just off the west coast of North Korea near Sinanju to retrieve Lt. Bill N. Garrett, who had crash-landed his disabled F-86 after sustaining battle damage in MiG Alley. The SA-16 pilot “landed in the water and quickly guided the plane toward the partly submerged mudflat where the Sabrejet pilot, having difficulty in swimming, was ducking under the water to avoid the enemy bullets.” As Mason’s amphibian closed to within about 100 yards of Garrett, his crew realized that the Sabre pilot was too exhausted to make it much farther. Despite enemy mortar and flak bursts, Mason “picked up the gear [and] opened the throttles and waddled up to him.” Reaching Garrett, the rescue crew hauled him aboard. With Captain Mason “alternating between reverse and forward thrust [the SA-16] splashed for deeper water,” and, after a few seconds’ delay which must have seemed like an eternity, managed to back out. Moments later, the SA-16 and its grateful passenger were on their way home.¹³

Lieutenant Garrett’s rescue was one of twelve SA-16 rescues of Sabre pilots in the war. F-86 pilots in trouble, who managed to reach the Yellow Sea—or at least the coastal mudflats, as in Garrett’s case—before abandoning their jets, permitted the SA-16 to take advantage of its capability of landing on the water. Moreover, the SA-16 also enjoyed speed and range advantages over the helicopters. Of the thirty-two F-86 pilots rescued from the Yellow Sea (excluding two who landed on Cho-do), SA-16s accounted for twelve, H-19s for twelve; helicopters (either H-5 or H-19) accounted

THE IMPORTANCE OF THE PICKUP OF SABRE PILOTS TO THE AIR SUPERIORITY MISSION COMES FROM LOOKING AT THE MIG KILLS ACHIEVED BY PREVIOUSLY RESCUED SABRE PILOTS

THE AWARENESS OF FRIENDLY AIR RESCUE AND SPECIAL OPERATIONS ASSETS MUST HAVE EASED THE ANXIETIES OF MANY PILOTS

for three, and in five cases the rescue vehicle was unidentified.¹⁴

On September 4, 1952, two Sabre pilots were picked up behind enemy lines. An H-19 from the 3d Air Rescue Squadron picked up one of the two men rescued that day, an SA-16 accounting for the other. Lt. Laverne G. Stange, 25th Fighter-Interceptor Squadron, had downed a MiG and in the process had sustained damage to his aircraft. Heading out to sea, Strange abandoned his jet and was preparing to be rescued by a Navy helicopter—which instead, apparently lost power and crashed into the water. Fortunately, an H-19 piloted by Maj. Roy A. Thompson, also was in the vicinity and after arriving on scene used the helicopter's hoist to pick up all three survivors—the two Navy crewmen and Stange.¹⁵

Only a month before the armistice, one of the few pickups of an F-86 pilot from an inland location behind enemy lines took place. On June 29, 1953, Maj. Flamm "Dee" Harper, 18th Fighter-Bomber Group, had his Sabrejet shot up on a bombing sortie over North Korea's Haeju Peninsula. Unable to make it out to sea with his aircraft on fire, he ejected over land about five miles from the coast. Landing hard on a boulder, he sustained broken ribs and temporary paralysis but managed to begin evading, intending to head for the coast. Discovering that his survival radio was dead, however, and realizing that his best signaling device was his parachute, Harper headed back to retrieve his chute. But two enemy soldiers had already noticed it. Harper shot both soldiers. F-84 Thunderjets having spotted him and relayed his position to the rescue helicopter, Harper recalled that a few minutes later, "certainly the most beautiful bird I had ever seen,"—an H-19—popped over the ridgeline above his head. Minutes later, hanging in the helicopter's sling, he was reeled in by a crewman, one of only five rescued "fighter-bomber" Sabre pilots in this study.¹⁶

Dramatic rescues notwithstanding, perhaps the most tangible way to measure the importance of the pickup of Sabre pilots to the air superiority mission comes from looking at the MiG kills achieved by previously rescued Sabre pilots. No fewer than seven Sabre pilots—three of them aces—went on to achieve 27 aerial victories following their rescues. Top-scoring triple ace Capt. Joseph C. McConnell, Jr., was rescued by helicopter from the Yellow Sea on April 12, 1953, and achieved eight of his sixteen aerial victories after that date. Contrary to the news stories, McConnell was picked up not by a 3d Air Rescue H-19 but by one belonging to a helicopter detachment of a special operations unit, the 581st Air Resupply and Communications Wing. At the time, however, the rescue was attributed to the 3d squadron, including the production of a staged photo since used in many publications, in an apparent attempt by Fifth Air Force to protect the identity of the classified helicopter detachment. Two other aces, Capt. Lonnie R. Moore, a double ace, and Clifford D. Jolley, earned 8.5 and 5.0 aerial victories, respec-

tively, following their rescues. Four lesser known Sabre pilots, Capt. Murray A. Winslow and Lts. Frank D. Frazier, Edmund G. Hepner, and Ira M. Porter, went on to earn a total of 5.5 aerial victory credits after their pickups. In addition to downing one MiG following his rescue in November 1952, Lieutenant Hepner was also credited with having damaged two MiGs. Others in addition to Hepner did likewise, but in a conflict with so many MiGs actually confirmed as destroyed—well over 800 for the entire war—the accounting of mere "damage" and "probable" downed MiGs, tended to be ignored. Thus, the rescues of Sabre pilots who continued to engage in aerial combat in Korea contributed even more to air superiority than can be measured simply by the tallying of aerial victories against MiGs.¹⁷

Another subtle aspect revealing the importance of the rescue of Sabre pilots to air superiority concerns the standard tactic of F-86s flying in two-ship formation during engagements with the enemy. The flight leader's job was to shoot down enemy aircraft; his wingman's job was to protect the leader from being "bounced" by MiGs. Most "kills" were achieved by flight leads, but in cases where there was a question of who had actually downed a MiG, the credit went to the leader, not his wingman. This increases the difficulty of gauging the importance to air superiority of the phenomenon of previously rescued wingmen going on to fly with leaders who achieved aerial victories. But it was a team effort, and wingmen were vital contributors to such victories.¹⁸

The case of Lt. Arthur J. Cuddy illustrates this point. On September 15, 1952, Cuddy, a wingman in the 336th Fighter-Interceptor Squadron, was forced to abandon his jet over the Yellow Sea. He was rescued by SA-16 and returned to combat status within 48 hours. Six days later, Cuddy flew as wingman for Capt. Robinson Risner when the latter downed two MiGs to become an ace. According to Risner's account, Cuddy "started a bounce on two MIG's," which led to Risner's first of two aerial victories that day. Although Cuddy received no official recognition, he had directly contributed to at least one of his flight leader's aerial victories, a feat made possible by Cuddy's rescue by SA-16. Moreover, one may speculate that Cuddy was better able to focus on the task at hand knowing from firsthand experience only days earlier that if he went down for any reason every effort would be made to bring him home.¹⁹

A third area of contribution concerned fighter pilot morale. Although less easily demonstrable than the aforementioned areas, one can readily imagine that the awareness of friendly Air Rescue and special operations assets must have eased the anxieties of many pilots to some degree. Those who owe their lives to an SA-16 or helicopter crew who plucked them from life-threatening circumstances often could not say enough about the importance of air rescue in the war. Several F-86 pilots provide a glimpse of the importance of knowing that someone would be looking for them, if not literally wait-



(Above) Lt. Norman E. Green was rescued from the Yellow Sea on April 12, 1953, by an SA-16. (Photo courtesy of N.E. Green)

ing for them to hit the water—as was sometimes the case for pilots ejecting in the “bail out” area near Cho-do. One 336th Fighter-Interceptor Squadron pilot, John E. Dews, Jr., thought that the presence of rescue assets played a “significant” part in maintaining fighter pilot morale. “They’d come get you,” recalled Dews, who on his fourth sortie of the day on April 1, 1952—flying “old 032,” reputedly the oldest and worst airplane in the 4th Fighter-Interceptor Group—was hit by MiGs and forced to roll over the side of his Sabre to get out. Dews was picked up by a 3d Air Rescue Squadron H-19 and flown to safety and medical care.

Lt. Col. (later Col.) Klair E. Back, who commanded 3d ARS for most of the war. (AFHRA Photo)



**WOULD-BE
RESCUERS
ALSO KNEW
THE PAIN OF
BEING
UNABLE TO
RETRIEVE
DOWNED
FLIERS**

Norman E. Green, of the 335th Fighter-Interceptor Squadron, rescued by SA-16 on April 12, 1953, put it succinctly: “The rescue and recovery pilots and crews were major players and contributors to the Air Force’s superiority in Korea. Fighter pilots could not have been so successful without them.” In another communication, Green expanded on his earlier thoughts:

*because of this [rescue] support we were able to put aside concerns for personal survival and were free to concentrate on shooting down MiGs. Confidence in the rescue services was so high we never questioned that they would be there if we needed them. And they certainly were.*²⁰

Richard W. Frailey, a Sabre pilot with the 334th Fighter-Interceptor Squadron, recalled that rescue was taught in the ground school known as “Clobber College” and that the knowledge of rescue assets “certainly did” impact morale favorably. Frailey’s own rescue by an SA-16 from the mouth of the Yalu River heightened his own remembrance of this aspect of the Korean War. On June 15, 1953, Frailey was inadvertently fired upon and shot down by his own flight lead, none other than Maj. James Jabara. Incidentally, Jabara received no aerial victory credit that day, while the Far East Air Forces Combat Operations Report stated innocuously that F-86 serial number 2923 (Frailey’s) was “lost opnl [operational], not due to eny [enemy] action. Plt [pilot] picked-up.”²¹

Six Sabre pilots and one F4U Corsair aviator—U.S. Marine Corps Capt. Jesse G. Folmar—were rescued on the same day they scored aerial victories (i.e., in most cases shortly if not immediately after having downed a MiG). The best known among that group was double-ace Maj. Frederick C. Blesse, who, on October 3, 1952, was forced to abandon his jet due to fuel exhaustion following combat in “MiG Alley” during which he had downed his ninth MiG to become a double ace. One can imagine the morale of Blesse’s fellow fighter pilots would have been hurt had the leading living ace at that time not been rescued shortly by SA-16 from the Yellow Sea. Others rescued were U.S. Marine Corps exchange pilot Maj. Alex J. Gillis, Maj. Vernon J. Lyle, Capt. Ken D. Chandler, and Lts. Ira M. Porter and Laverne G. Stange—all of the USAF. Undoubtedly, the fact that none of these MiG killers were lost must have bolstered morale in their units.²²

But despite many successes, would-be rescuers also knew the pain of being unable to retrieve downed fliers known to have been alive on the ground after going down in enemy territory. On February 3, 1952, Lt. Charles R. Spath, 334th Fighter-Interceptor Squadron, was forced to abandon his jet over North Korea. Later, a flight mate observed Lieutenant Spath on the ground. Using his survival radio, the lieutenant reported that he was unable to walk due to a broken leg. A friendly guerrilla team located nearby, monitoring the same radio frequency that Spath was using,

“YOU CAN CHALK ME OFF FOR SAYING THIS, BUT GET THE HELL OUT OF HERE, IT’S A TRAP.”

MiG killers in the 4th FIG, in August 1952. Maj. Frederick C. Blesse (top left) was rescued by an SA-16 on October 3, 1952, just after downing his ninth MiG. (AFHRA Photo)



decided to intervene. Four of the guerrillas reached Spath ahead of the enemy soldiers also in the vicinity and moved him to a secure location. Some time later, the guerrilla team made contact with Fifth Air Force intelligence personnel who began coordinating a rescue attempt. Capt. Gail W. Poulton, an H-19 pilot in the 3d Air Rescue Squadron, was offered the mission, which would be particularly hazardous due to the high elevation of the area. After several weeks of meticulous planning, the mission was a “go.” Because of certain pieces of information that had been coming from Spath and the guerrillas that somehow didn’t seem to fit, Poulton was concerned that the rescue attempt might already have been compromised. Unfortunately, his hunch was correct. Approaching the intended pickup area, Poulton contacted Spath by radio and asked him how many people were at the landing site with him. Spath replied, “I don’t know.” Suspicious, Poulton asked several more questions to which he received equally ambiguous responses. Finally, Poulton said, “We are here to pick you up, if everything down there is OK. You are giving me uncooperative and unclear answers.... I have leveled off and discontinued my approach ...and we’ll abort this rescue attempt if you don’t answer my questions fully...in the next 15 seconds.” Spath responded quietly, “you can

chalk me off for saying this, but get the hell out of here, it’s a trap.” Tragically, Spath died in captivity some weeks later.²³

In another valorous but unsuccessful rescue attempt a year later, an H-19 belonging to the classified helicopter detachment of the 581st Air Resupply and Communications Wing

*flew to an area just twenty-six miles from the Chinese city of Antung in an attempt to pick up a downed British exchange pilot whose location had been reported. Before dawn on March 27, 1953, an SA-16...escorted the H-19 from Cho-do to the vicinity of a peninsula near Ch’olsan, North Korea, orbited offshore at low altitude [in an extremely vulnerable position] while the H-19 searched for the pilot, and escorted the helicopter on its return to Cho-do.*²⁴

Although the H-19 copilot, Robert F. Sullivan, did not recall the downed pilot’s identity, most likely it was Squadron Leader Graham S. Hulse, a Royal Air Force exchange pilot assigned to the 336th Fighter-Interceptor Squadron. Two weeks earlier, on March 13, Hulse had been forced to abandon his F-86 over North Korea following aerial combat in which he was credited with one-half an aerial victory against a MiG. Apparently, Fifth Air Force intelligence had believed him to be an evader or in the care of friendly guerrillas, hence the reason for the attempted rescue on what was one of the deepest penetrations of the war by helicopter. But the H-19 located only a concentration of well-armed enemy troops in the area in which Hulse had been reported, was fired upon, and barely made it back to Cho-do on its remaining fuel, landing on the beach. Sadly, the British pilot’s story, whether of Hulse or someone else, remains unsolved. But it is noteworthy that in this case crews belonging to the Air Rescue and “special ops” communities—the SA-16 and H-19, respectively—teamed up for the attempted, if unsuccessful, Sabre pilot pickup.²⁵

Thus, fifty years ago in Korea the U.S. Air Force’s Air Rescue and special operations communities performed an overlooked but critical role contributing to the all-important air superiority mission in the war. On at least two occasions, helicopters picked up key components of downed MiG-15s which increased the Sabre pilots’ technical knowledge of the enemy’s new jet fighter. H-19 and H-5 helicopters and SA-16 amphibians retrieved at least forty-one F-86 pilots from North Korea or the northern waters of the Yellow Sea to “fly and fight” again, at least seven of whom went on to down MiGs in aerial combat. And, perhaps, most important, the presence of Air Rescue and “special ops” aircrews lifted the morale of our fighter pilots who always knew in the back of their minds, and as General Short’s companion put it, “that you were gonna spend everything you had to go in and get him.” The barren hills and icy waters of Korea were where that legacy was born, a legacy alive and well today.²⁶ ■

NOTES

1. An earlier version of this paper was presented at the Pacific Air Forces Korean War Symposium, Honolulu, Hawaii, Jun. 25-28, 2001. The author gratefully acknowledges the assistance of the following individuals: Larry Davis, editor of *SabreJet Classics*; Ron Maynard, DoD POW/Missing Personnel Office, Arlington, Va.; Ron Thurlow, Beaver Creek, Ohio; Dr. Timothy Warnock, Air Force Historical Research Agency (AFHRA hereinafter), Maxwell AFB, Ala.; and Prof. Kenneth Werrell, College of Aerospace Doctrine, Research, and Education, Maxwell AFB, Ala. Note that this study focuses on operations conducted by USAF Air Rescue Service ("Air Rescue" hereinafter) and "special operations" aircraft. While fully aware that in some cases F-86 pilots were returned home from behind enemy lines in operations involving crash boats, ground parties, guerrilla forces, and other means, those rescues are beyond the scope of this study.
2. Intvw, Lt. Gen. Michael C. Short, USAF, with PBS, n.d.
3. Hist., Fifth Air Force (FAF), Jan.-Jun. 1951, vol. II (AFHRA); Oral History Intvw (OHI), Gen. Earle E. Partridge with U.S. Air Force Academy (USAF) interviewer, Feb. 16, 1977, pp. 62-64 (AFHRA).
4. *Ibid.* See *Air Power History*, Michael E. Haas, "In the Devil's Shadow," Vol. 48, No. 4, (Winter 2001): 18-27; another Korean War participant, Col. Frank E. Merritt, said of Nichols: "He was an amazing person who'd go behind the lines.... spoke Korean fluently, and was loved by all the South Koreans.... in fact General Rhee [the South Korean president] would take this man's word over anybody's.... He would even bring pictures back that we couldn't believe that he was able to get." See OHI, Merritt with USAFA interviewer, Dec. 8, 1977, pp. 17, 59-60 (AFHRA).
5. Hist., FAF, Jan.-Jun. 1951, vol. II (AFHRA).
6. Forrest L. Marion, unpublished manuscript written for Air Force Special Operations Command History Office (AFSOC hereinafter), Hurlburt Field, Fla., "Air Force Special Operations Korean War Chronology," Aug. 3, 1998; *FAF Intelligence Summary*, Aug. 16-Sep. 15, 1951.
7. Note that this figure does not take into account pilots picked up on the friendly side of the front or from waters just off the coast of friendly-controlled territory, such as the Han River estuary or more southern coastal areas. If such rescues were included, the figure would be somewhat higher. Edward B. Crevonis and Howard Meeks, compilers, "Study of the Third Air Rescue Squadron in Relation to the Korean War, Period Covered May 1, 1950 to Dec. 31, 1950," p. 117 (AFHRA); *USAF Credits For The Destruction Of Enemy Aircraft, Korean War* (Washington, D.C., 1975), p. 36. See table on page 23.
8. Intvw, Hughes with author, Honolulu, Hawaii, Jun 26, 2001; Richard C. Kirkland, *Tales of a War Pilot* (Washington and London, 1999), p. 112.
9. Earl H. Tilford, Jr., *Search and Rescue in Southeast Asia* (Washington, D.C.: Office of Air Force History, 1992), pp. 5-14; Forrest L. Marion, "The Grand Experiment: Detachment F's Helicopter Combat Operations in Korea, 1950-1953," *Air Power History* Vol. 40, No. 2 (Summer 1993): 48-51.
10. James I. Bonini, "Take the Easy Way," *Combat Crew* [Strategic Air Command], May 1965, pp. 13-15; telephone intvw, Bonini with author, Feb. 7, 2001; Table 1, "F-86 Pilots Rescued"; Frederick C. Blesse, *No Guts, No Glory* (Nellis AFB, Nev., 1955), p. 46.
11. *USAF Credits*, pp. 29, 34; See table on page 23.
12. Intvw, Rowe with author, Honolulu, Hawaii, Jun 27, 2001; Michael M. Boll, unpublished MS, AWC, "Soviet-American Air Combat over Korea," San Jose State Univ.
13. Hist., 3d Air Rescue Squadron (3 ARS) (Flt C, Pt IV), Oct 1951 (AFHRA); "Third Air Rescue Squadron Saves 100th Downed Pilot," *Misawa Air Base Piloteer*, copy of article located in Hist., 3 ARS, Nov. 1951 (AFHRA). This copy does not identify the source but likely was the Misawa base paper. The SA-16 pilot, Robert C. Mason, served in Flight C, 3 ARS, stationed at Misawa AB, Japan; e-mails, Mason to author, Dec. 14, 1999; Mason to Dr. Ken Werrell, Jun. 13, 2000.
14. Forrest L. Marion, "The Dumbo's will get us in no time: Air Force SA-16 Combat Operations in the Korean War Theater, 1950-1953," *Air Power History* Vol. 46, No. 2 (Summer 1999): 27; Table 1, "F-86 Pilots Rescued."
15. *Air Force Times*, Sep. 27, 1952; The other four days on which two Sabre pilots were rescued from behind enemy lines were Jun. 7 and Nov. 21, 1952; Apr. 12 and May 17, 1953. See table on page 23.
16. [Flamm] Dee Harper, "No. 1 Snafu," *SabreJet Classics* 4 (Fall 1996): 7-11; e-mail, Harper to author, Sep. 28, 2000;
17. A. Timothy Warnock, ed., *USAF in Korea: A Chronology, 1950-1953* (Washington, D.C., 2000), p. 80; Michael E. Haas, *Apollo's Warriors: United States Air Force Special Operations during the Cold War* (Maxwell AFB, Ala., 1997), p. 89. See table on page 23.
18. Intvw, John E. Dews with author, Maxwell AFB, Ala., Dec. 10, 1999; telephone intvw, Bonini with author, Feb. 7, 2001; John Lowery, "MiG Fever," *Air and Space Smithsonian* Vol. 14 (Apr./May 99): 16-17; ltr, Lowery to Perry Turner (editor, *Air and Space Smithsonian*), Jun. 9, 1999, copy in possession of author.
19. "MIG Killers," *Air Reservist*, Feb. 1953, 4.
20. Dews intvw; ltr, Green to author, Sep. 10, 2000, and telephone intvw with author, Jan. 23, 2001; ltr, Green to author, Jan. 23, 2001; Green's Individual Flight Record (Air Force Form 5), Apr. 1953, copy in possession of author.
21. Intvw, Frailey with author, Dec. 8, 1999; Lowery, "MiG Fever," pp. 16-17; Hqs., Far East Air Forces Daily Combat Operations Reports, Jun. 1953 (AFHRA); See table on page 23.
22. Roy A. Grossnick, *United States Naval Aviation, 1910-1995* (Washington, 1997), p. 768; Hist., 3 Air Rescue Group (38 ARS, Pt IV), Jul.-Dec. 1952 (AFHRA); *USAF Credits*, pp 5, 7, 14, 23, 29, 34.
23. Gail W. Poulton, unpublished ms., "Jell Green-4, Another Sad Ending!" included in materials provided to AFHRA, George A. Hagelthorn to Capt. Donna B. Roberts (AFHRA), Aug. 2, 1999, copy in possession of author. Note that the selflessness and valor of Lieutenant Spath were not always manifested in similar circumstances. In another case, on May 24, 1953, a "snatch recovery" equipped C-47 was apparently drawn into a trap and fired upon as it passed overhead a downed B-29 pilot who had reported that the area was clear for the attempted pickup; see "Aborted rescue haunts Santa Fe pilot," *Santa Fe New Mexican*, Dec. 29, 1997; Intvw, Col. David M. Taylor (USAF, Ret.) with author, Jul. 8, 1998, Charlottesville, Va., copies of audio tape at AFHRA and AFSOC.
24. Marion, "The Dumbo's will get us," p. 26.
25. *Ibid.*, p. 29; ltr, Sullivan to author, May 17, 1995; various communications, Sullivan with author, 1995-2000; *USAF Credits*, p. 18. The H-19 aircraft commander was Capt. Frank Westerman; the SA-16 aircraft commander was Lt. Augusto D. Muzio. The British Ministry of Defence's Air Historical Branch Casualty Index lists Squadron Leader Hulse as presumed killed on Mar. 13, 1953; ltr, Alan Thomas to author, Feb. 3, 2000.
26. Air Rescue Service held the lion's share of USAF helicopter capability and airframes during the Korean War. In the last decade and a half the balance of the Air Force's rotary-winged capability has shifted to the "special operations" community.

Bernard Schriever and the Scientific Vision





Stephen B. Johnson

(Overleaf) Maj. Gen. Bernard A. Schriever, and Jim Dempsey, Atlas Program Manager for Convair, escort a group of congressional leaders on a tour of the Atlas missile production line.

(Right) Maj. Gen. Bernard A. Schriever.

SCHRIEVER WOULD MEET SOME OF THE NATION'S MOST BRILLIANT SCIENTISTS

SCHRIEVER PROMOTED TWO MAJOR IDEAS: THAT SCIENTIFICALLY-DRIVEN INNOVATION WAS CRUCIAL TO THE AIR FORCE, AND THAT MANAGEMENT OF THESE INNOVATIONS REQUIRED LEADERSHIP AND AUTHORITY

World War I was won by brawn, and World War II by logistics. World War III will be won by brains.

General "Hap" Arnold, circa 1945¹

Although World War II, according to Army Air Forces (AAF) Commanding General Henry H. "Hap" Arnold, was won by logistics, the development of radical new technologies during the war left a lasting imprint on the AAF leader. Radar, atom bombs, and jet aircraft made it clear that the next war would look little like the last. After the war, Arnold ensured that the (AAF) would foster relationships with the scientists and engineers who created the technologies needed to win the next war. Perhaps the most important of Arnold's postwar actions to ensure technological prowess was to place his protege, a little-known colonel, in the new position of scientific liaison. The choice of Col. Bernard Schriever to be the Air Force's scientific point man would prove to be a masterstroke.

As scientific liaison, Schriever would meet some of the nation's most brilliant scientists, who after World War II would move into prominent positions of power. Schriever would find himself appointed to progressively more influential positions in the Air Force, heading the United States' top priority intercontinental ballistic missile (ICBM) program with unprecedented authority, and eventually leading the Air Force Systems Command, itself based upon Schriever's design.

Schriever promoted two major ideas: that scientifically-driven innovation was crucial to the Air Force, and that management of these innovations required leadership and authority just as much as the operational Air Force. Inspired by the scientists' vision of technical change, Schriever led the Air Force's development of ballistic missiles, and then its push into space. His career showed that the Air Force need not wait for technical development, but could lead and direct it.

Early Career—An Introduction to the Scientists

Bernard Schriever was born on September 14, 1910 in Bremen, Germany. After his father, who worked in the merchant marine, was interned in New York in 1916, the rest of the family came to the United States, settling in Texas where some of his father's relatives lived. After his father died in 1918, in an industrial accident, his mother had to raise Bernard and his brother Gerhard by working as a housekeeper, and selling refreshments at a golf course.²

Stephen B. Johnson is an associate professor of space studies at the University of North Dakota, Grand Forks. He edits Quest: The History of Space Flight Quarterly. Dr. Johnson earned a Ph.D. in the history of science and technology at the University of Minnesota, Minneapolis. His book, The United States Air Force and the Culture of Innovation, is forthcoming from the Air Force History and Museums Program. Additionally, he has submitted a book manuscript to Johns Hopkins University Press, titled "The Secret of Apollo: Systems Management in American and European Space Programs." Dr. Johnson has published articles in several journals.



Bernard worked at the local golf course, becoming an exceptional golfer in the process, a skill that would serve him well in his military career. He graduated in architectural engineering from Texas A&M, and then became a reserve officer in the Army Air Corps. In 1933, upon completion of flight training, he became a bomber pilot and maintenance officer under Lt. Col. "Hap" Arnold. The two became close, partly because of the friendship between Schriever's mother and Arnold's wife. Arnold became Schriever's mentor and friend, even so far as hosting Schriever's wedding in 1938 at Arnold's home. Schriever, who at that time had left the Air Corps to be a pilot for Northwest Airlines after failing to acquire a regular commission, reapplied, becoming a second lieutenant in October 1938.³

Before the United States' entry into World War II, the Air Corps assigned Schriever to be a flight instructor, engineering officer, and test pilot, before attending the Air Corps Engineering School and then Stanford University from 1940 to June 1942. After receiving his masters degree in aeronautical engineering from Stanford, the Corps sent Major Schriever to the 19th Bombardment Group as the chief maintenance officer. He flew about thirty-six combat missions in the Pacific, and by the end of the war, had been promoted to colonel as commander of Advanced Headquarters, Far East Air Service Command. Since much of his work involved logistics, Schriever made critical contacts with officers from Air Materiel Command at Wright Field.⁴



(Above) Dr. Theodore von Kármán, Brig. Gen. Donald L. Putt, and Dr. Albert E. Lombard, Jr. (left to right), three of the Air Force's most important scientific personnel.

(Right) Dr. Ivan Getting.

SCHRIEVER HAD A HAND IN CREATING THE AIR FORCE'S RESEARCH AND DEVELOPMENT (R&D) INFRASTRUCTURE ... AT CAPE CANAVERAL, FLORIDA, IN THE MOJAVE DESERT NORTH OF LOS ANGELES, AND RESEARCH CENTERS IN TENNESSEE AND AT HANSCOM FIELD, NEAR BOSTON

After the war's end, General Arnold, now the Army Air Forces Commanding General, acted to maintain the partnership between military officers and scientists that had been so beneficial during the war. One new organization created to aid this collaboration was the RAND Corporation, spun off from an operations analysis group of the Douglas Aircraft Corporation.⁵ Another was the Scientific Advisory Board (SAB), recommended and then initially chaired by eminent California Institute of Technology aerodynamicist Theodore von Kármán.⁶ The SAB, established in June 1946, was to act as a semi-permanent adviser to the AAF Staff.⁷

Arnold recognized that an external board of scientists would have little influence unless he also created internal positions that would act as bridges and advocates for scientific ideas. For this purpose he established the Office of Scientific Liaison under the Assistant Chief of Staff, Materiel, and elevated Schriever to be its first director in 1946. During his three years as Scientific Liaison, Schriever had a hand in creating the Air Force's research and development (R&D) infrastructure. These included test facilities at Cape Canaveral, Florida, in the Mojave Desert north of Los Angeles, and research centers in Tennessee and at Hanscom Field, near Boston. From these activities, he became familiar with most of the Air Force's budding R&D.

One of Schriever's main jobs as Scientific Liaison was to work with the Scientific Advisory Board, meeting many of the nation's leading physical scientists.⁸ Among the more important scientists that he came to know during this time were von Kármán, Princeton mathematician John von Neumann, and Massachusetts Institute of Technology physicists George Valley and Ivan Getting. This experience had a profound effect on Schriever's thinking, as he learned the possibilities and implications of the latest discoveries in science and technology. Schriever came to have a tremendous respect for these men and their visions for the future. Many years later, Schriever stated that

I became really a disciple of the scientists who were working with us in the Pentagon, the RAND Corporation also, so that I felt very strongly that the

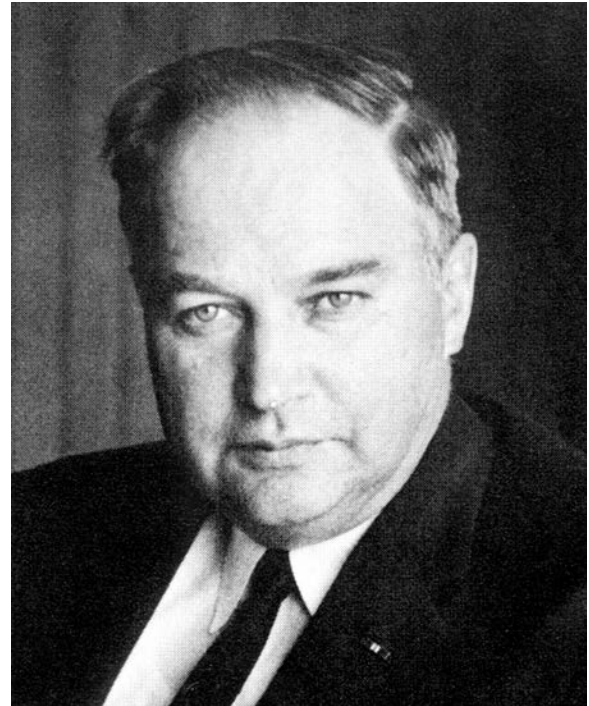

scientists had a broader view and had more capabilities. We needed engineers, that's for sure, but engineers were trained more in a...narrow track having to do with materials than with vision.⁹

With scientific prestige at unprecedented high levels after the development of radar and atomic weapons during World War II, scientists placed in positions of power throughout the defense establishment became powerful advocates for the Air Force. Because of Schriever's profound respect for their opinions and ideas, they became strong allies, with access to leaders at the highest levels of the Air Force, the Department of Defense, Congress, and even to the President. Schriever would consistently use their advice and expertise through the formation and use of advisory panels and boards. These relationships would serve him well as he moved to his next major assignment, to create plans for the Air Force's future weapons.

Scientific Vision in the Development Planning Office

After a stint at the National War College in 1949 and early 1950, the Air Force assigned Schriever to the office of the Assistant for Evaluation in the newly formed office of the Deputy Chief of Staff, Development (DCS/D). The DCS/D office came about as part of the reorganization of the Air Force to separate R&D from Air Material Command into the new Air Research and Development Command, which came into official existence on January 23, 1950.¹⁰

The chief of the Assistant for Evaluation Office was Dr. Ivan Getting, who had been the Chairman of the Electronics Committee of the Research and Development Board.¹¹ Getting assigned his deputy, Colonel Bernard Schriever, responsibility

SCHRIEVER BECAME THE POINT MAN FOR THE NEW POLICIES AND PROCEDURES FOR TECHNOLOGY DEVELOPMENT

THE NEW PROCEDURES REQUIRED AN ANALYSIS OF FUTURE TECHNOLOGIES, STRATEGIES, AND OBJECTIVES USING SYSTEMS ANALYSIS

THESE NEW, CONTROVERSIAL METHODS LED TO BATTLES BETWEEN SCHRIEVER, AND OFFICERS WITH A SHORTER-TERM VIEW

for strategic matters, while others handled tactical issues, air defense, guidance, and so on.¹²

One major task of the Assistant for Evaluation was to make plans for the development of future Air Force systems and technologies. The first attempt in this direction began in August 1950, as Getting's office was to begin "immediate preparation of development planning objectives which would point out the goal of research and development effort in relation to the strategic and operational plans of the Air Force. Such objectives would take into account future combat conditions, possibly enemy and U.S. capabilities, major requirements, etc."¹³

These objectives would then form the basis for allocating and programming of R&D funding. To generate development objectives, Getting's office could look in two directions: "operations pull" from the needs of current operations through the Directorate of Requirements, or "technology push" from the expertise of scientists and technologists. For the latter, they had ready access to the RAND Corporation specialists in analysis of future systems. In July 1951, four RAND personnel relocated to the DCS/D office under Getting, now renamed the Assistant for Development Planning.¹⁴ They assisted with the creation of "development planning objectives," or goals for new technology development. Others in the DCS/D office would translate these objectives into "General Operational Requirements," then into specific orders known as "Development Directives," and finally, allocate funds based upon these prioritized directives.¹⁵

In the spring of 1951, Getting left for an executive post at Raytheon, and Schriever took his place as Assistant for Development Planning.¹⁶ He, therefore, became the point man for the new policies and procedures for technology development. Contrary to the earlier practice of asking the operational commands what their needs were, the new procedures required an analysis of future technologies, strategies, and objectives using systems analysis along with requirements from current operations to establish development planning objectives for future systems. These new, controversial methods led to battles between Schriever, who represented the scientists and the long-term future of the Air Force, with officers with a shorter-term view of their needs, like the powerful Vice Chief of Staff, Gen. Curtis E. LeMay, who vigorously fought some of Schriever's recommendations. As Schriever put it, he did not win too many of these battles, except on missiles, where there were fewer entrenched interests.¹⁷

A more immediate problem facing Schriever's office was a result of the Korean War. The Air Force found itself with numerous unusable aircraft, leading Vice Chief of Staff Nathan F. Twining, in January 1951, to start an investigation of the Air Force's development and maintenance processes. DCS/D chief Lt. Gen. Gordon Saville ordered the formation of a study group led by Schriever to analyze the problem.¹⁸

The group completed its study in April 1951,

and released an influential staff paper called "Combat Ready Aircraft." It pinpointed two major problems with current aircraft: requirements based on short term factors, leading to continuous modifications, and insufficient coordination and direction of all elements of the "complete weapon."¹⁹ To solve these problems, the group recommended that the Air Force create an organization and process with responsibility and authority over the complete weapon by adding "planning, budgeting, programming, and control" into the functions of the responsible Air Force organizations. These organizations were to have total control over an entire project, enforced through full budget authority.²⁰ The study group suggested that the Air Force let prime contracts to a single contractor to integrate the entire weapon, and that the Air Force organize on a project basis as well. Project-centered organization and simultaneous planning of all components throughout the "life cycle" of the weapon defined the "weapon system concept."²¹

Under the weapon system concept, the Air Force gave industry substantial authority. With it, the Air Force "purchased *management of new weapon system development and production*,"²² reducing government involvement in the design and supply of equipment. One way to do this was through the prime contractor method, where the government gave funding to one company to manage and integrate the entire system. A second way was the associate contractor method, where the government hired one company to create the specifications and oversee the system development, and hired others to develop the component hardware.²³ When using this method, Air Force officers had to act as the integrators.

Through 1952 and 1953, Colonel Schriever became an active proponent the systems approach, which spread through ARDC and the DCS/D. His leadership of the "Combat Ready Aircraft" study led Schriever to a deeper appreciation of the nuances of management. These new skills would become critical for the remainder of his career, which was about to skyrocket into the Air Force's hierarchical stratosphere.

From Vision to Implementation—Western Development Division

Ballistic missile programs had languished at a low priority during and after World War II, as the Air Force concentrated its efforts first on manned bombers, and then on jet fighters for the Korean War. Air Materiel Command ran the Air Force's program, and monitored competing Army and Navy missile programs.²⁴

The rapidly escalating Cold War provided the impetus to transform the loosely organized, low-priority missile projects. Successful testing of the Soviet atomic bomb in 1949, and the hydrogen bomb in 1953, led to a major shift in the pace and priority of missile development in the United States.²⁵ As the chief of the Development Planning

Trevor Gardner, Assistant Secretary of the Air Force for Research and Development.

SCIENTISTS WOULD SOON DEVELOP NUCLEAR WARHEADS OF SMALL ENOUGH SIZE AND LARGE ENOUGH EXPLOSIVE POWER TO BE PLACED ON ICBMS

THE TEAPOT COMMITTEE RECOMMENDED THAT ICBMS BE DEVELOPED

Office in early 1953, Colonel Bernard Schriever learned of the success of American thermonuclear tests at a Scientific Advisory Board meeting in March 1953. Recognizing the implications of this news for ICBMs, Schriever met with John von Neumann at his Princeton, New Jersey, office later that month. Von Neumann, a consultant both to the Atomic Energy Commission, and to Convair for its Atlas ICBM program, confirmed Schriever's opinion. Scientists would soon develop nuclear warheads of small enough size and large enough explosive power to be placed on ICBMs. Because of its speed and invulnerability, this was the preferred method for nuclear weapons delivery. Realizing that he needed official evidence, Schriever talked with James Doolittle, who approached Chief of Staff Vandenberg to get the Scientific Advisory Board to investigate the question.²⁶

The Nuclear Weapons Panel of the Scientific Advisory Board, headed by von Neumann, reported to the Air Force Staff in October 1953. In the meantime, Trevor Gardner, Special Assistant to the Secretary of the Air Force for Research and Development, volunteered to head a Department of Defense Study Group on Guided Missiles. Gardner learned of the progress of the Atlas program from the contractor, General Dynamics Convair Division. Based on the results of Gardner's study group, Gardner and Air Force Secretary Harold Talbott formed the Strategic Missiles Evaluation Committee, or "Teapot Committee" headed by von Neumann to investigate and recommend a course of action for strategic ballistic missiles.²⁷

Trevor Gardner selected the newly-created Ramo-Wooldridge Corporation (R-W) to administer the daily operations of the study.²⁸ Gardner was a friend of Dr. Simon Ramo, the co-founder of R-W, for they had lived in the same apartment house years earlier when both worked at General Electric. When Gardner and the Air Force came calling, the new company was still small and looking for business.²⁹

In February 1954 the Teapot Committee recommended that ICBMs be developed "to the maximum extent that technology would allow." They also recommended the creation of an organization that hearkened back to the Manhattan Project and Radiation Laboratory of World War II:

*The nature of the task for this new agency requires that over-all technical direction be in the hands of an unusually competent group of scientists and engineers capable of making systems analyses, supervising the research phases, and completely controlling the experimental and hardware phases of the program—the present ones as well as the subsequent ones that will have to be initiated.*³⁰

On May 14, 1954, the Air Force made Atlas its highest R&D priority. Because Convair, in San Diego, had the most advanced ICBM program, and because the majority of the aircraft industry was



located in southern California, the Air Force established their ICBM development organization in a vacant church building in Inglewood, California. The Air Force initially planned to give command of the new organization to Maj. Gen. James McCormack, who had been a special assistant to the DCS/D. Health problems forced him out of the picture, and instead Air Force leaders placed newly promoted Brig. Gen. Schriever in command of the new Western Development Division (WDD) of Air Research and Development Command (ARDC), taking command on August 2, 1954. Since the Teapot Committee had recommended creation of a "Manhattan-like" project organization, one of Schriever's first problems was to see if this made sense, and determine who would oversee the technical aspects of the project.³¹

Because neither he nor the scientists believed that the Air Force had the technical expertise to manage the ICBM program, Schriever had two options: hiring Convair as prime contractor, or hiring Ramo-Wooldridge as the system integrator, and Convair and other contractors as associate contractors. Hiring Convair assumed that they had the wherewithal to design and build the product. Schriever was already unhappy with Convair's lack of subcontracting on Atlas, and believed that it did not have the requisite expertise.³²

Schriever was also deeply influenced by his scientific advisors, with whom he had worked for nearly a decade. Von Neumann and his fellow scientists on the Nuclear Weapons Panel of the Scientific Advisory Board believed the Soviet threat to be serious. This threat required a response just as extraordinary as the Manhattan Project had been a decade earlier, to bring together the nation's best scientists to marry ballistic missiles to thermonuclear warheads. Because the govern-

WITH HIS ORGANIZATIONAL FOUNDATIONS SET, SCHRIEVER'S IMMEDIATE TASK WAS TO PUSH ICBM DEVELOPMENT RAPIDLY FORWARD

SCHRIEVER CONVINCED THE AIR FORCE'S TOP BRASS OF THE NECESSITY OF A SECOND, TWO-STAGE DESIGN

GARDNER AND SCHRIEVER BRIEFED PRESIDENT DWIGHT D. EISENHOWER IN JULY 1955

ment could not hire the needed expertise on civil service pay scales, Schriever and the Nuclear Weapons Panel believed a civilian organization would be necessary to mobilize scientific expertise. Schriever later explained:

Complex requirements of the ICBM and the predominant role of systems engineering in insuring that the requirements were met, demanded an across-the-board competence in the physical sciences not to be found in existing organizations. Scientists rated the aircraft industry relatively weak in this phase of engineering, which was closely tied to recent advances in physics. The aircraft industry, moreover, was heavily committed on major projects, as shown by existing backlogs. Its ability to hire the necessary scientific and engineering talent at existing pay-scales was doubted, and with the profit motive dominant, scientists would not be particularly attracted to the low-level positions accorded to such personnel in industry.³³

To capitalize on the vision and expertise of physical scientists and mathematicians, such as, von Neumann and von Karman, Schriever created an organizational scheme whereby the leading scientists could help guide the ICBM program. Following the recommendations of von Neumann's committee, Schriever hired Ramo-Wooldridge (R-W) for systems engineering and integration.³⁴ Free of civil service regulations, and without significant contracts or conflicts of interest, R-W could hire the requisite scientific and technical talent. Air Force officers could more easily direct R-W than Convair, because R-W had few other contracts and no production capability. The aircraft industry disputed this unusual arrangement, fearing that it established a precedent for "strong system management control" by the Air Force, and also that it might create a powerful new competitor with inside information on Air Force contracts and contractor capabilities.³⁵

Organizational Structure of the Inglewood Complex

Schriever had the luxury of selecting the best officers from throughout the Air Force. Selecting the most skilled officers, Schriever's talented staff quickly took charge of ICBM development. Because Air Materiel Command (AMC) retained authority for procurement, it set up a field office alongside Schriever's ARDC staff in Inglewood. By early September, when Air Force headquarters signed off on the selection of Ramo-Wooldridge, the triumvirate of organizations, the WDD, the Special Aircraft Project Office (SAPO) of AMC, and R-W completed the government's project organization.³⁶

With his organizational foundations set, Schriever's immediate task was to push ICBM development rapidly forward, and within a year to create a detailed plan for the effort. For the first time, Schriever was in charge of a major development project, providing an opportunity to imple-

ment his management ideas. Schriever believed strongly in the military doctrine of ensuring that management responsibility, authority, and accountability went hand in hand. Much to his annoyance, he found instead that Air Force standard processes and regulations put significant limits on his authority.

Schriever first had to deal with Convair's rebellion against Ramo-Wooldridge. Most aircraft industry leaders believed themselves capable of building ICBMs, and backed Convair. They did not want their authority usurped by this upstart, and they feared the emergence of R-W as a dangerous new competitor.³⁷ They also feared lower profits due to tighter Air Force control. Schriever recognized the danger, stating that "the project office has been no match for the powerful pressure that industry can, and has, exerted at political and high military levels."³⁸ Not until mid-1955 did Convair acquiesce, realizing that they needed to hire highly educated scientists and engineers to appease the Air Force's scientific advisors, and to gain electronics capability. Schriever, in turn, restricted R-W to maintain aircraft industry support. On February 24, 1955, the Air Force prohibited R-W from engaging in ICBM hardware production.³⁹

R-W proved its worth by its investigation of Convair's nose-cone design. Working with the Atomic Energy Commission and other scientists, R-W scientists and engineers found that Convair's nose-cone design suffered from excessive reentry heating. R-W's alternative blunt nose cone design greatly decreased the temperatures, and also decreased the weight by half. This in turn decreased launch vehicle size from 460,000 to 240,000 pounds, and reduced the number of engines from five to three. This dramatic improvement convinced Schriever, his team, and his superior officers that the selection of R-W had been correct.⁴⁰

Due to the uncertainties of the radical new ballistic missile designs, R-W and the Air Force promoted alternative designs for various components, subsystems, and even entire vehicles. By April 1955, Schriever convinced the Air Force's top brass of the necessity of a second, two-stage design, and by the next month, Schriever's complex of the WDD, SAPO, and R-W was working on Atlas, the two-stage Titan, and the Thor tactical ballistic missile.⁴¹

To accelerate ICBM development Schriever needed freedom from bureaucratic delays. Schriever found that the approval process required thirty-eight Air Force and DOD approvals or concurrences, and five separate budget appropriations. Frustrated with the delays, Gardner and Schriever decided that they had to increase Schriever's authority and funding, and decrease the number of organizations that could oversee and delay the program. Finding support in Congress and within the Eisenhower Administration, Gardner and Schriever briefed President Dwight D. Eisenhower in July 1955, eventually convincing him and Vice-President Richard M.

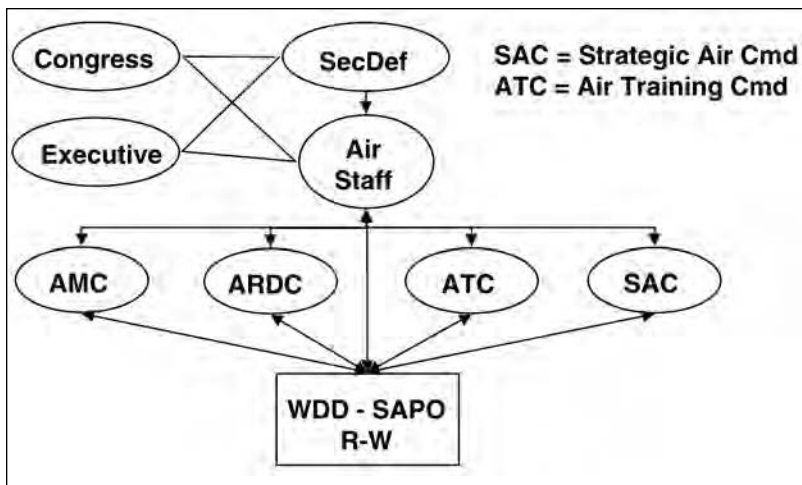

Pre-Gillette organization of ballistic missile development.

Nixon—with John von Neumann’s timely support—to make ICBMs the nation’s top defense priority.⁴²

Pre-Gillette Organization of Ballistic Missile Development

With the President’s endorsement in hand by September, Gardner and Schriever formed a study group to recommend organizational changes to streamline the program. As Schriever put it later, “... we loaded [the committee]... pretty much with people who knew and who would come up with the right answers...” Hyde Gillette, the Deputy for Budget and Program Management in the Office of the Secretary of the Air Force, chaired the group, which not surprisingly enhanced Schriever’s authority.⁴³

The Gillette Procedures. Solid lines show the direct chain of authority. Air Force’s commands had no authority over ballistic missile development, and the Air Staff had input only through the DOD Ballistic Missile Committee.

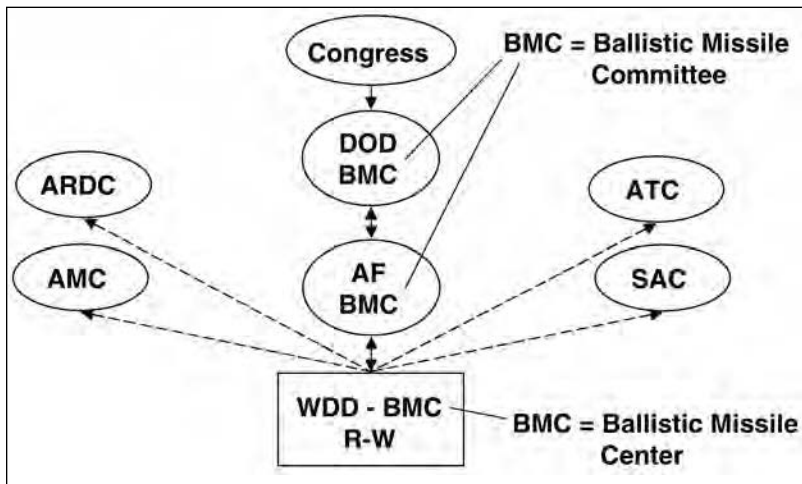

The “Gillette Procedures,” approved by Secretary of Defense Charles Wilson on November 8, 1955, funnelled all ballistic missile decisions through annual meetings of the newly formed Ballistic Missiles Committee in the Office of the Secretary of Defense. Although evading ARDC and AMC for approvals and decisions, Schriever’s organization needed to provide information to these two Air Force organizations. Schriever stated that “we had to give them information because they provide a lot of support, you see, so it wasn’t the

fact that we were trying to bypass them. We just didn’t want to have a lot of peons at the various staff levels so they could get their fingers on it.” No longer could various Air Force and DOD organizations modify the program through piecemeal changes. The new procedures had the intended effect, for by 1958, AMC officers cut industrial facility lead-time from 251 to 43 days.⁴⁴

Many in the Air Force did not take ballistic missiles very seriously. Col. Ray Soper, one of Schriever’s trusted subordinates, noted that “the Ops [operational commands] attitude, at the Pentagon, was to let the ‘longhairs’ develop the system—they really didn’t take a very serious view of the ballistic missile, for it was thought to be more a psychological weapon than anything else.”⁴⁵

The Gillette procedures provided Schriever with both technical and budget authority, making it one of the first full applications of project management in the Air Force. With this new authority, Schriever developed his own approach to management, which he would call “concurrency.” The concept, formulated in the “Combat Ready Aircraft” study, required detailed planning and control of the entire weapon’s life cycle right from the start. In the fall of 1954 Schriever and his staff developed a Management Control System. Every month, they required the Air Force, R-W, and associate contractors to fill out standardized status report forms. One of Schriever’s officers had sole control of these updated the master schedules, placed on the walls of a guarded Program Control Room. This room served a dual purpose, as the place where managers could quickly assess the “official” status of the program, and as a public relations tool where Schriever and his deputies showed the program status and innovative management to visitors.⁴⁶

Schriever instituted monthly conferences known as “Black Saturdays” for project officers to report difficulties. At these meetings, Schriever, along with his top Ramo-Wooldridge and military staff, reviewed the entire program, and assigned all problems at the meeting to individuals there. These meetings endeavored to bring problems forward instead of sweeping them under the rug. As Schriever put it, “the successes and failures of all the departments get a good airing.”⁴⁷

Rapid development implied not only the parallel planning of all system elements, but also their concurrent development, telescoping several typically serial activities into parallel ones. Schriever did not invent the process, but rather coined the term “concurrency” as a way of explaining it to outsiders.⁴⁸ Along with the Program Control Room, it gave his organization an aura of competence that helped protect it from detailed scrutiny.⁴⁹

In the beginning, Schriever’s style of management might best be called “enlightened ad-hocracy” for its informality and inattention to financial or legal details. He and his team organized informally to achieve tasks as rapidly as possible, leaving others to clean up the cost and legal mess.

**SCHRIEVER'S
"NEED FOR
SPEED" LED
TO
EXTENSIVE
USE OF
LETTER
CONTRACTS**

**AIR FORCE
HEADQUAR-
TERS HAD TO
COPE WITH
THE LEGAL
AND
FINANCIAL
MESS**

**CONCUR-
RENCY
AMPLIFIED
TECHNICAL
PROBLEMS**

Ad hoc teams came and went, formed to solve particular problems, and dissolving when they solved them.

Schriever's "need for speed" led to extensive use of letter contracts through 1954 and 1955. Procurement officials in the SAPO and technical officers in the WDD realized that they needed to track expenditures relative to technical progress, but the rapid pace of the program and the lack of documentation quickly led to a financial and contractual morass. Complicated by the WDD's lack of personnel, and the issuance of technical directives through R-W, contractual problems became a major headache, and a source of friction between Schriever and AMC.⁵⁰

The Procurement Staff Division of the Ballistic Missiles Office at Air Force headquarters had to cope with the legal and financial mess. They insisted that "the technical directives [be] covered by cost estimates." Schriever fought these regulations as "examples of the 'law's delay,' but in the end had to give in. To ensure that Ramo-Woolbridge and the other contractors documented technical directives, the Guidance Branch of WDD in October 1956 "began holding a contract administration meeting immediately after each technical directive meeting.... By January 1957, the Procurement Staff Division extended the practice to all contracts involving technical direction and to all technical direction meetings."⁵¹

Although Schriever could and did shrug off cost factors and bureaucratic snafus, he could not ignore technical problems. Unfortunately for Schriever and his preference to reduce bureaucracy, concurrency amplified technical problems, which his team discovered when ballistic missile testing began in late 1956 and 1957. Already by 1955, each of the military services recognized that rocket reliability was a difficult problem, with ARDC sponsoring a special symposium to discuss the subject.⁵² Two-thirds of missile failures were due to electronic components, such as vacuum tubes, wires, and relays. Electromagnetic interference and radio signals caused a significant number of failures, and about 20 percent of the problems were mechanical, dominated by hydraulic leaks.⁵³

Atlas was no different. The first two Atlas tests in mid-1957 ended with engine failures, but the third succeeded, leading to a record of three successes and five failures for the initial Atlas A test series. Similar statistics marked the Atlas B and C series tests between July 1958 and August 1959. For Atlas D, the first missiles in the operational configuration, reliability improved to 68 percent. Of the 13 failures in the Atlas D series, personnel errors caused four, five were random partial failures, two caused by engine problems, and two were design flaws uncovered through testing.⁵⁴ In 1960, two accidents dramatized the reliability problem. In March an Atlas missile exploded, destroying its test facilities at Vandenberg Air Force Base on the California coast. Then, in December, the first Titan I blew up along with its test facilities at

Vandenberg. With missile reliability continuing to hover at the 50 percent range for Atlas, and a somewhat better 66 percent for Titan, ICBM reliability problems drew Air Force and congressional studies and investigations.⁵⁵

To fix the problems, the Air Force and R-W created new organizational processes to find problems and ensure high quality.⁵⁶ These included exhaustive testing, component inspection and tracking, and configuration control to ensure that the design matched the hardware actually launched. The application of these systems engineering concepts eventually led to success, particularly on the Minuteman program, where they were consistently applied. Concurrency, when combined with the added techniques required to ensure dependability, was a powerful method to develop large-scale technologies rapidly.

Spreading Concurrency through ARDC

While Schriever's organizations in Southern California struggled to make Atlas fly, Air Force headquarters underwent serious soul-searching regarding the Air Force's R&D processes in the wake of the Soviet launch of *Sputnik* in October 1957. The resulting study by the Scientific Advisory Board, known as the Stever Committee Report, recommended that ARDC be authorized its own R&D funding (then mostly allocated through AMC), and that budgets be prepared on program lines as implemented by the Gillette Procedures for ballistic missiles.⁵⁷

Gen. Samuel Anderson, then head of ARDC, followed up the Stever Report with an internal study, eventually known as the "Anderson Committee Report." This report, issued in February 1959, concurred with the Stever recommendations, except in its organizational proposals. Instead of the functional organization recommended by Stever's group, the Anderson Committee proposed that ARDC's functions be realigned into four major "product" groupings: aerodynamics, ballistic missiles, and space systems, electronic systems, and basic research. Since Anderson was to leave his post to become head of AMC, he decided to leave the committee recommendations for the next commander, none other than Lt. Gen. Schriever.⁵⁸

In April 1959, Schriever became the head of ARDC, and the next month he launched his own study, headed by Col. Jewell Maxwell, to investigate how to incorporate concurrency throughout ARDC. The Maxwell group report, submitted at the end of July, agreed with the organizational structure of the Anderson group as the best way to implement Schriever's methods.⁵⁹

At the same time, Schriever's rising star drew positive attention at the Air Staff, as they appointed a high-level group headed by Anderson, the AMC commander, to examine the entire Air Force procedure for management of large systems. This "Weapons Systems Study Group," which included Schriever, investigated the applicability of Schriever's "concurrency" methods throughout



THE STUDY GROUP AGREED THAT SCHRIEVER'S INGLEWOOD METHODS SHOULD BE ADOPTED

REGULATIONS FOR SYSTEMS MANAGEMENT, KNOWN AS THE "375-SERIES" REGULATIONS, WERE PUBLISHED ON AUGUST 31, 1960

the Air Force's R&D organizations.⁶⁰ The study group agreed that Schriever's Inglewood methods should be adopted, with the planning and implementation of new systems on a systems, or "life cycle" basis. Planning for the entire system would occur up front, and the project offices would have the authority to manage the development, including authority over the funding. However, the group split into three camps regarding the actual organization. Ultimately the Air Staff selected the least ambitious plan, which extended Schriever's methods of concurrency to aeronautics and electronics, as well as ballistic missiles and space systems. The plan required the development of formal procedures that would apply to all large-scale Air Force development programs.⁶¹

The first three regulations for systems management, known as the "375-series" regulations, were published on August 31, 1960, and were subsequently revised and extended.⁶² The 375 regulations formally applied the ARDC-AMC project office concept across the Air Force's other large acquisition programs. They gave project officers substantial authority to carry out their programs without micro-management from Air Force or ARDC headquarters, and specified the documents and information required by both headquarters for program approval and periodic reporting. Through their application across ballistic missiles, aeronautics, and electronics, they provided a uniform standard for the commanders of ARDC and AMC to control all of their large projects, and through the methods of concurrency implied therein, to speed them up. Schriever's processes were triumphant. However, his organizational plan was not.

During the Anderson Committee deliberations, Schriever had presented the most radical ideas. He proposed a new split of functions, giving ARDC the entire acquisition process, and leaving long-term

logistics to the remnants of AMC. In essence, Schriever proposed to expand his own power at the expense of AMC, by taking over more of the procurement process, and leaving AMC only with maintenance of operational systems.⁶³ The committee accepted "Inglewood-style" procedures, but not Schriever's reorganization of AMC and ARDC. However, with the accession of Robert S. McNamara to the Secretary of Defense, Schriever's radical proposal would get another chance.

The issue that catalyzed the Air Force to revisit Schriever's plan was the growing importance of space technologies and missions. Soon after the launch of *Sputnik* in October 1957, the military services were competing and bickering over space projects. Continuing squabbles inspired the Eisenhower Administration and Congress to create the National Aeronautics and Space Administration (NASA) to run the civilian space program, and the Advanced Research Projects Agency (ARPA) to manage the DOD's space programs. The Air Force, which had been running the WS-117L program to develop military reconnaissance satellites, thus found its authority for the project usurped by the new agency. To regain what they believed to be the "natural" extension of their service from air to space, the Air Force would have to prove its managerial, organizational, and technical competence. Fortunately for the Air Force, the ARPA effort foundered, and the services once again regained a measure of control over their space projects. However, the Air Force did not gain the primacy and control of military space that it desired. The next major opportunity for change would come in the new Kennedy administration in 1961.

For President Kennedy's new appointee for the Secretary of Defense, Robert McNamara, managerial and organizational factors counted most. Deputy Secretary of Defense Roswell Gilpatric hinted that they might assign the military space mission to the Air Force upon proper reorganization of space efforts into a single command with more centralized control. Schriever had already investigated this possibility in 1960, when he asked his old friend Trevor Gardner, then president of Hycon Manufacturing, to head a committee to study the Air Force's organization for space. Gardner's committee recommended that the Air Force separate its space programs into a new division, apart from ballistic missiles. With Gilpatric's carrot in hand, Schriever combined the Gardner committee recommendations with the "Schriever plan" presented in the previous year to the Anderson Committee. With the Air Force's space mission at stake versus the Army and Navy, Chief of Staff Thomas D. White approved Schriever's previously rejected reorganization. Secretary of the Air Force Eugene Zuckert, and Secretary of Defense Robert McNamara quickly approved, and on March 8, 1961, McNamara conferred all space research to the Air Force.⁶⁴

On March 14, 1961, Gen. White assigned AMC's procurement activities to an expanded ARDC, now



(Above) Secretary of Defense Robert S. McNamara (center) visits Vandenberg AFB in March 1962, with President John F. Kennedy (left of center, looking left).

(Right) Roswell Gilpatric.

WITH THE CREATION OF AFSC WITH SCHRIEVER AS ITS COMMANDER, SCHRIEVER'S POWER AND INFLUENCE REACHED ITS APEX

SCHRIEVER'S METHODS WOULD CONTINUE TO SPREAD, BUT WOULD SLIP FROM HIS CONTROL

redesignated Air Force Systems Command (AFSC). AMC itself was deactivated, and replaced by a smaller Air Force Logistics Command (AFLC). AFSC, which came into being on April 1, 1961, had four major elements, the Ballistic Systems Division (BSD) based in San Bernardino, California; Space Systems Division (SSD) in El Segundo, California; Aeronautical Systems Division (ASD) in Dayton, Ohio; and Electronics Systems Division (ESD) in Lexington, Massachusetts.⁶⁵

With the creation of AFSC with Schriever as its commander, Schriever's power and influence reached its apex. The adoption of the 375 procedures and the creation of AFSC and its four systems divisions standardized the Air Force acquisition process on the "Inglewood Model." AFSC eliminated the problems of ARDC-AMC joint command by combining their functions under Schriever. The 375 procedures spread systems management throughout the Air Force, but also brought Inglewood back under Air Force control, negating the DOD control of ballistic missiles through the Gillette Procedures of 1955. Under the old system, Schriever's authority stemmed from his influence outside the Air Force through his powerful scientific and civilian allies such as John von Neumann and Trevor Gardner. Under the new system, Schriever's power remained, but now firmly ensconced in the Air Force hierarchy. Schriever's methods would continue to spread, but would slip from his control into the hands of arch-manager Robert McNamara.⁶⁶

Improving Management: Schriever in the McNamara Era

From the creation of the Office of the Secretary of Defense in 1947, until the height of McNamara's reign in the mid-1960s, the Office of the Secretary of Defense grew in power, pulling critical decisions up the hierarchy, and subordinating service interests and rivalries. The Defense Department Reorganization Act of 1958 created unified operational commands, further enlarged the Department of Defense, and gave more authority to the Secretary of Defense. To end the bickering over



radical new weapons and missions, the Act allowed the Secretary of Defense to reassign combat functions and the development and operation of new weapons without congressional approval, and also gave him the authority to create a single supply agency for all of the services. Finally, recognizing the importance of new technologies, the Act created the new post of the Director of Defense Research and Engineering, with authority over all research and engineering within the Department of Defense. This sweeping Act provided the authority and justification for a strong manager to take control of the Department. Such a manager arrived with the next administration.

Robert McNamara, appointed as Secretary of Defense early in 1961,⁶⁷ was famous for his belief in centralized control implemented through quantitative measurement. He spent the spring of 1961 gathering information about the Department, initiating over 100 studies known as "McNamara's 100 trombones," or "the 92 Labors of Secretary McNamara."⁶⁸ Initially, his reception in the Pentagon and in Congress was favorable, as he moved rapidly to understand the military's problems and to deal with them. Soon, the services realized that McNamara really did intend to manage them as he was accustomed to doing in corporate America, and fought him as best they could. McNamara implemented the Programming, Planning, and Budgeting System (PPBS) so quickly that the services did not realize what had hit them. With PPBS, and a cadre of the Air Force's own RAND Corporation economic experts to lead the efforts, McNamara had the means to exercise truly centralized management of the services.

These trends were clear to Schriever and his R&D groups as they were to others. Col. Otto Glasser, of AFSC headquarters, summarized the new trends at a 1962 conference. He stated,

MCNAMARA'S
OFFICE
IMPLE-
MENTED
PHASED
PROJECT
PLANNING,
STARTING ON
THE AIR
FORCE'S
PROPOSED
TITAN III

REPLACING
CONCUR-
RENCY, MAN-
AGERIAL
REFORM AND
COST
CONTROL
SOON
BECAME
SCHRIEVER'S
NEW WATCH-
WORDS

“Dominant among all of the external influences in systems management is the trend toward centralized civilian control.”⁶⁹ Due in large degree to the complexity and cost of new weapon systems, the “validation of requirements [for a weapon system] can no longer be left to the possible parochial opinions of a single service... The requirements of today must be national and they must be validated in detail before a program can be seriously undertaken.”⁷⁰

Upper management evaluated proposed systems primarily on the basis of cost-effectiveness. Once approved, they subjected programs to continual review.⁷¹ As Glasser put it, the reforms “seem to be in the direction that you would go in handling your own household budget and I believe that it is safe to say that is just how the average taxpayer expects us to employ the tax dollars.” On the other hand, there were dangers. He compared current management to the old-style “efficiency experts.”

The efficiency expert is not a creator, but rather an improver on other people's creations. For a limited period, the benefits of his labors can be enormous, but care must be taken to avoid stifling all new ideas. There can be no bold approaches when the program must be defined in explicit detail before initiation. If an approach must survive the review of a series of boards, panels, committees, advisors, etc., before it can be started, it is safe to say that the technology it employs will be the least common denominator among these many reviewers, and we risk the danger inherent in the story that “a camel is a horse designed by a committee.”⁷²

To ensure that DOD executive management had a say in project planning, budgeting, and approval, McNamara's office implemented phased project planning, starting on the Air Force's proposed Titan III project to lift the proposed hypersonic test vehicle, the Dyna-Soar. Phased planning required an additional step of “preliminary design” between feasibility studies and full-scale development, for the purpose of better defining technical requirements, and most importantly, more accurate cost estimates.⁷³ The new process added six months to a year to every development project, causing Schriever to dourly comment, “If we are to be held to this overly conservative approach, I fear the timid will replace the bold and we will not be able to provide the advanced weapons the future of the nation demands.”⁷⁴

The AFSC commander sensed the change in national priorities, and recognized the impetus behind McNamara's reforms. By 1962, studies by Harvard and RAND economists had shown that Department of Defense weapons projects had consistently large overruns and schedule slips, with missile programs having the worst record. The RAND study showed that over six missile projects, costs overran by more than a factor of four, with schedule slips over 50 percent. Other projects showed smaller slips, but all types averaged at least 70 percent cost overruns, and the average

over 200 percent—triple the original estimates. With such a record, the military was clearly vulnerable to criticism on cost issues.⁷⁵

Replacing concurrency, managerial reform and cost control soon became Schriever's new watchwords. His immediate problem was to respond vigorously to the McNamara-Rubel initiatives, which he saw as cost control measures.⁷⁶ In a February 1962 memorandum to the Air Force Chief of Staff, Gen. Curtis LeMay, Schriever stated that cost overruns arose from “any one or a combination of” factors, including deliberate underestimation, adhering to overly strict standards, over optimism in estimating performance and schedules, vacillation or changes in program direction, and inadequate military or contractor management.⁷⁷

One area that Schriever had to improve was cost estimation, so he gave his comptroller's office the task. They began by educating his staff, instituting cost analysis training courses at the Air Force Institute of Technology in Dayton, Ohio. By February 1962, the first class of 25 students graduated from this course. Schriever intended to train 125 more. AFSC also developed a new report, the “Program Planning Report.” This report, “received enthusiastically” by the Office of the Secretary of Defense and the Bureau of the Budget, allowed for improved analysis of cost data with respect to technical and schedule progress.

Schriever also standardized communications throughout AFSC. By mid-1961, Schriever's organization molded status reporting into a highly sophisticated system, known as Rainbow Reporting because it presented each element of the system on differently colored pages in a small, brightly packaged booklet that specified the formats and procedures for status reports and presentations. Over the next few years, these procedures evolved to include full program, yearly, and monthly milestone schedules, government and contractor financial data, contractor manpower data, reliability data, procurement data, engineering qualification data, and the so-called special PRESTO procedures for problems that needed immediate attention. For each item, it gave example forms along with specifications of the information to be included, when the information was to be reported, and to whom.⁷⁸

To improve cost and schedule estimation, AFSC adopted and modified the Navy's new planning tool, the Program Evaluation and Review Technique (PERT). PERT used mathematical network techniques to connect schedule events to estimate the overall schedule. Schriever “expended considerable effort to improve basic PERT.” With “advanced PERT,” Schriever found that industry was “anxious to participate in order to improve its own management” in the use and improvement of PERT.⁷⁹

Education was a primary means to attain higher reliability. AFSC enrolled fifteen officers in the Masters program in Reliability Engineering at the Case Institute of Technology and in a course at the Air Force Institute of Technology. The Air

This test launch of an Atlas E ICBM took place in 1960, and flew 7,000 statute miles down range.



SCHRIEVER DEVELOPED OTHER WAYS TO IMPROVE AFSC'S MANAGEMENT CAPABILITIES

Logistics School established a course in reliability, and more than 250 AFSC personnel completed a course in reliability from the Institute of Radio Engineers and the American Society for Quality Control. All new contracts required the use of the new reliability specification, while AFSC reported progress in a semi-annual Reliability Status Report. Enforcement of reliability standards emphasized the necessity of conservative designs in the McNamara regime.⁸⁰

Schriever developed other ways to improve AFSC's management capabilities. He established a Management Improvement Board, whose purpose was to "energize a vigorous program of management improvement and to provide overall guidance and direction to our management efforts." The Board was "made up of General Officers having the greatest experience in systems management matters ranging from funding, systems engineering, procurement and production, through research and development." Schriever had it examine "the entire area of systems management methods to include those of the Industrial complex as well as those of the Air Force." He also reinstated the Air Force Industry Advisory Group, a Board of Visitors to improve working relationships with industry, and a program of "systems management program surveys." AFSC also collected "lessons learned" information from programs,⁸¹ and broadcast this information through publications and industry symposia.⁸² Schriever also used this information to produce management goals for AFSC.⁸³

Despite his dislike for McNamara's centralizing changes, which removed decision-making from the Air Force to the Office of the Secretary

HE ALSO REINSTITATED ... A BOARD OF VISITORS TO IMPROVE WORKING RELATIONSHIPS

of Defense,⁸⁴ Schriever emphasized management at AFSC, both for the better efficiency of AFSC itself, and to improve AFSC's position as a management innovator. His initiatives resulted in the imposition of strong project management organizations in AFSC and in its industry contractors, in detailed "feedback and control" mechanisms used in day-to-day management, and in educational and communication mechanisms to transmit these methods to AFSC and industry. Schriever forcefully imposed his management methods throughout AFSC, and through its officers and publications they would influence many others.

McNamara, duly impressed with the procedures and reforms in Schriever's organization, used them in part as the basis for the Department of Defense's new regulations for the development of large-scale weapon systems. In 1965, the Department of Defense enshrined phased planning and the systems concept as the cornerstone of its R&D regulations. Having already spread to NASA, these processes moved throughout the aerospace and computing industries. Even when not explicitly used, the assumptions and ideas encompassed in these regulations became an accepted element of the culture of innovation in both.⁸⁵

Conclusion: Implementing the Scientific Vision through Better Management

Schriever's "Inglewood model" of technological development was adopted across the Air Force. In this model, extensive up-front planning at the air staff level would set top level system requirements, and then an "empowered" project office would be given the authority to develop the system. Using commands had some influence in setting the initial requirements, but their influence during development was limited. This view was a "revolutionary" model of technical development based on Schriever's belief in the "scientific vision." To make rapid development of radical technologies, management became a primary issue, one that Schriever paid increasing attention to from the moment he took charge of the ICBM program to his retirement from the Air Force in 1966. To this day Schriever believes that management and organization are critical to the future of the Air Force, just as it has been since World War II and the Cold War.

Through two decades from 1945 to 1965 when the Air Force developed its organization and processes for complex technology development, Bernard Schriever was at the epicenter of events. He helped create the SAB and ARDC in the 1940s. In the early 1950s in the Development Planning Office, Schriever helped establish systems analysis as a standard Air Force procedure to set requirements for new technologies. He headed the ballistic missile effort from 1953 to 1959, at which point he spearheaded the transition from ARDC to AF Systems Command (AFSC), and the creation of the 375 series of systems management regulations for

the Air Force. Finally, he was at the helm of AFSC during the early 1960s, when Robert McNamara standardized systems management through the Department of Defense.

The organizational reforms that Schriever had directed caught the attention of arch-manager Robert McNamara in the early 1960s. Whereas Schriever's centralization aimed to speed development and give authority to project managers, McNamara used centralization to control costs and reduce duplication. Much to Schriever's dismay, McNamara found the Inglewood model congenial, for it developed the communication and control methods necessary to control technical development. McNamara needed only minor modifications such as phased planning to transform the Inglewood model into a centralized planning and budgeting system across all of the services. Systems management thus spread through all of the services, tying proven R&D methods to civilian managerial control. With systems management, the Department of Defense could now plan and control technical development for its own ends.

Military officers and historians most frequently remember Schriever for his path breaking work in ballistic missiles. However, his influence is much more pervasive than "merely" the architect of the Air Force's missile and space programs. Schriever was critical to the Air Force, because he was a

strategic bridge between the technologists and the Air Force. He helped bring into the Air Force the three major methods created in the 1940s and 1950s to deal with complex technologies: operations research, project management, and systems engineering. Operations research was the scientists' means to analyze complex human-machine systems. Project management became the manager's fundamental means to organize complex systems, and system engineering was the engineering mechanism to coordinate them.

Schriever was the key mediator who transformed these methods into standard processes in the Air Force and the Department of Defense. Although Schriever and his deputy Charles Terhune both later lamented the formation of the 375 procedures because they "removed flexibility," the fact remains that using them the Air Force has been highly successful at developing and deploying technologies. When used as guidelines for technology development, the 375 procedures encapsulated many of the critical lessons and methods developed in the 1950s. More than any other single individual, Bernard Schriever deserves the credit (or blame!) for merging scientific and engineering vision with military procedures to create the methods now standard throughout the Department of Defense. Technological change is now a standard expectation of the United States military establishment.⁸⁶ ■

NOTES

1. Quote from Arnold related by Bernard A. Schriever, telephone interview with author, Mar. 4, 1999, Washington, D.C.
2. John Clayton Lonquest, "The Face of Atlas: General Bernard Schriever and the Development of the Atlas Intercontinental Ballistic Missile 1953-1960," Ph.D. diss., Duke University, 1996, chapter 2.
3. *Ibid.* Jacob Neufeld, "Bernard A. Schriever: Challenging the Unknown," in John L. Frisbee, ed., *Makers of the United States Air Force* (Washington, D.C.: Office of Air Force History, 1987), pp. 281-83.
4. Lonquest, chapter 2. Bernard Schriever, telephone interview with author, Mar. 4, 1999.
5. Bruce L. R. Smith, *The RAND Corporation*, (Cambridge, Mass.: Harvard University Press, 1966). David R. Jardini, "Out of the Blue Yonder: The RAND Corporation's Diversification into Social Welfare Research, 1946-1968," Ph.D. dissertation, Carnegie Mellon University, 1996.
6. "Where We Stand," August 22, 1945, and "Toward New Horizons," Dec. 15, 1945. Both can be found in Michael H. Gorn, ed., *Prophecy Fulfilled: "Toward New Horizons" and Its Legacy*, (Washington, D.C.: Air Force History and Museums Program, 1994).
7. Thomas A. Sturm, *The USAF Scientific Advisory Board: Its First Twenty Years 1944-1964*, (Washington, D.C.: USAF Historical Division Liaison Office, 1967). Donald Ralph Baucom, "Air Force Images of Research and Development and Their Reflections in Organizational Structure and Management Policies," Ph.D. diss., University of Oklahoma, 1976.
8. Lonquest, "The Face of Atlas," pp. 57-59. Neufeld, "Bernard A. Schriever: Challenging the Unknown," pp. 281-84. Schriever, interview with author, Mar. 4, 1999.
9. Schriever, interview with author, Mar. 25, 1999.
10. Michael H. Gorn, *Vulcan's Forge: The Making of an Air Force Command for Weapons Acquisition, 1950-1985* (Washington, D.C.: Office of History, Air Force Systems Command, 1989), pp. 7-19. Dennis J. Stanley, and John J. Weaver, *An Air Force Command for R&D, 1949-1976: The History of ARDC/AFSC*, (Washington, D. C.: Office of History, Air Force Systems Command, 1976).
11. Ivan Getting, *All in a Lifetime: Science in the Defense of Democracy*, (New York: Vantage, 1989), pp. 225-27.
12. *Ibid.*, pp. 228-30.
13. J. P. Thornton, *History of the Deputy Chief of Staff, Development, 1 July to 31 December 1950*, AFHRA K140.01, p. 14.
14. *Ibid.*, pp. 3-4; Getting, *All in a Lifetime*, pp. 240-41, Getting interview; Schriever, interview with author, Mar. 4, 1999.
15. Gorn, *Vulcan's Forge*, pp. 29-31.
16. Getting, *All in a Lifetime*, p. 241.
17. Lt. Gen. Donald L. Putt, Oral History Program Interview with James C. Hasdorff, Apr. 1-3, 1974, AFHRA K239.0512-724, pp. 44-45. General Bernard A. Schriever, Oral History Interview with Dr. Edgar F. Puryear, Jr., June 15-29, 1977, AFHRA K239.0512-1492, pp. 5-6. Lonquest, "The Face of Atlas," pp. 57-64. Author's interview with Schriever, Mar. 4, 25, Apr. 13, 1999.
18. "Combat Ready Aircraft," p. 2.
19. *Ibid.*, pp. 9-14.
20. *Ibid.*, p. 15.
21. *Ibid.*, pp. 19-24.
22. Robert J. Reed, "New AF Policy Means More Competition—More Selling," *Aviation Age* 19:8 (Aug. 1953): 21, italics are Reed's.
23. *Ibid.*, p. 22.

24. Edmund Beard, *Developing the ICBM: A Study in Bureaucratic Politics*, (New York: Columbia University Press, 1976), pp. 16-20, 120-28.
25. Some good introductions into the Cold War literature include: Richard Crockatt, *The Fifty Years War: The United States and the Soviet Union in World Politics, 1941-1991*, (New York: Routledge, 1995), Walter Lafeber, *America, Russia, and the Cold War 1945-1992*, 7th edition, (New York: McGraw-Hill, 1993), Paul Dukes, *The Last Great Game* (New York: St. Martin's Press, 1989), and Stephen J. Whitfield, *The Culture of the Cold War* (Baltimore: Johns Hopkins University Press, 1991). John Lewis Gaddis, *We Now Know: Rethinking Cold War History*, (New York: Oxford University Press, 1997). Martin Walker, *The Cold War: A History*, (New York: Henry Holt, 1995).
26. Lonnquest, "The Face of Atlas," pp. 82-97. Schriever, interview with author, Mar. 4, 1999.
27. Lonnquest, "The Face of Atlas," pp. 98-112.
28. Jacob Neufeld, *Ballistic Missiles in the United States Air Force 1945-1960*, (Washington, D.C.: Office of Air Force History, United States Air Force, 1990), pp. 98-99. Donald McKenzie, *Inventing Accuracy: A Historical Sociology of Nuclear Missile Guidance*, (Cambridge, Mass.: MIT Press, 1990), pp. 109-10. Lonnquest, "The Face of Atlas," pp. 113-16.
29. Simon Ramo, telephone interview with author, Dec. 7, 1999. Davis Dyer, *TRW: Pioneering Technology and Innovation Since 1900*, (Boston: Harvard Business School Press, 1998), pp. 163-64, 168-71.
30. "Recommendations of the Tea Pot Committee," Feb. 1, 1954, in Neufeld, *Ballistic Missiles*, pp. 260-61.
31. Neufeld, *Ballistic Missiles*, p. 106. *Space and Missile Systems Organization: A Chronology, 1954-1979*, Office of History, Headquarters, Space Division, AFSC Historical Publication. Schriever, interview with author, Mar. 25, 1999.
32. In this context, "in-house" means that Convair elected to build these components inside the company, instead of purchasing them from outside. Schriever, interview with author, April 13, 1999.
33. House Committee on Government Operations, *Organization and Management of Missile Programs*, 86th Congress, 1st Session, House Report No. 1121, 1959, p. 75.
34. Lonnquest, pp. 163-70. Beard, pp. 172-78. Beard believed that the use of Ramo-Wooldridge was a "fait accompli," since Trevor Gardner personally promoted the use of R-W in this capacity. Beard interpreted Schriever's defense of R-W as due to higher-level influences, since Gardner was one of Schriever's most important supporters. As we have seen, Schriever had many other reasons to favor the R-W solution. One was his bias to accept the views of the scientists from his previous experience as Scientific Liaison. Equally important, he accepted the concept of military-civilian partnership for systems integration, just as Getting had done at the Radiation Laboratory. This would have been much more difficult with the large Convair organization than Ramo and Wooldridge's new company. One problem with prime contractors was that they could bury problems at lower levels from Air Force view. This was far less likely under the associate contractor method. See Neufeld, Jacob, ed., *Reflections on Research and Development in the United States Air Force: An Interview with General Bernard A. Schriever and Generals Samuel C. Phillips, Robert T. Marsh, and James H. Doolittle, and Dr. Ivan A. Getting*, conducted by Dr. Richard Kohn, (Washington, D.C.: Center for Air Force History, 1993), pp. 62-63 for Ivan Getting's comments on this based on his experience at Raytheon, a subcontractor on the B-58 program.
35. Neufeld, *Ballistic Missiles*, p. 114. Ivan A. Getting, letter to author, Jun. 18, 1999.
36. Lonnquest, p. 262-63.
37. For the early history of Atlas, see Neufeld, *Ballistic Missiles*, pp. 44-50, 68-79. Memo to General Power from General Schriever, Subject: Airframe Industries vs Air Force ICBM management, ca. Dec. 1954, AFHRA Microfilm 35257.
38. Memo, Schriever to Power, Airframe Industries vs Air Force ICBM management.
39. Ltr to all centers from Lt. Gen. Thomas Power, February 24, 1955, Subject: Eligibility of the Ramo-Wooldridge Corporation and Thompson Products, Inc. to bid, AFHRA Microfilm 35258, 168.7171-80. Memo to Col. Ford from Gen. Schriever, subject: General Dynamics - Convair propaganda campaign, Mar. 18, 1955, AFHRA Microfilm 35257.
40. Rough draft of "The Atlas Nose Cone", Dec. 12, 1956, AFHRA Microfilm 35267.
41. *Space and Missile Systems Organization: A Chronology*, pp. 26-27. Neufeld, *Ballistic Missiles*, pp. 119-30.
42. Neufeld, *Ballistic Missiles*, pp. 138-39. Lonnquest, pp. 224-44. Memo to Col. Sheppard from Gen. Schriever, Subject: Subject presentation, Apr. 1, 1955, AFHRA Microfilm 35257. *Space and Missile Systems Organization: A Chronology*, p. 27.
43. Lonnquest, pp. 245-48. Gen. Bernard A. Schriever, Oral History Interview with Dr. Edgar F. Puryear, Jr., Jun. 15 and 29, 1977, AFHRA K239.0512-1492, p. 3. Neufeld, *Reflection on R&D in the USAF*, pp. 56-57. *Space and Missile Systems Organization: A Chronology*, pp. 28-29. Memo to Trevor Gardner from Gen. Schriever, Sep. 6, 1955, subject: Meeting on 6 September 1955 to Discuss Management Fund for ICBM Program, AFHRA Microfilm 35258, 168.7171-80. Ethel M. DeHaven, *Aerospace: The Evolution of USAF Weapons Acquisition Policy 1945-1961*, Volume 6, History of DCAS—1961, (Los Angeles: Air Force Systems Command, 1962), pp. 43-44.
44. Schriever interview with Puryear, p. 6. Neufeld, *Ballistic Missiles*, pp. 136-37. Gillette Report, Nov. 10, 1955, in Neufeld, *Ballistic Missiles*, p. 279. *Organization and Management of Missile Programs*, Eleventh Report by the Committee on Government Operations, 86th Congress, 1st Session, House Report No. 1121, (Washington, D.C.: Government Printing Office, 1959), pp. 23-29. DeHaven, *Aerospace*, pp. 53-54.
45. "Notes transcribed from an interview conversation with Col. Ray E. Soper, Vice Commander BSD, on the final day of his service with USAF before retirement," BSD(BEH) NAFB, Cal 92409, Nov. 29, 1966, AFHRA Microfilm 30015, p. 3.
46. Some historians have questioned whether the Control Room served any real purpose aside from showmanship. My conclusion is that some of the people in the WDD saw that it had a "show" purpose, and concluded that is all that it was for. After interviewing Charles Terhune, I am convinced that it served a real purpose in giving the "official" status at any time, and in providing a central information repository. See Charles Terhune, telephone interviews with author, Sep.-Oct. 1998, Washington, D.C.; Schriever, interview with author, Mar. 4, 1999.
47. Lonnquest, pp. 258-59, 266-67, 291-97. Schriever, interview with author, March 4, 1999. Schriever believes that the idea for "Black Saturday" was his own, because his philosophy of management was to dig out the problems, and not to spend time on the status of things that were going well. He did not recall seeing this practice on any other programs at that time. It also seems that Schriever's group soon began to use computers for the MCS, with Ramo-Wooldridge. This would make it one of the earliest applications of computers to management communication.
48. Lonnquest, pp. 300-302.
49. A similar phenomenon appeared in the use of the Program Evaluation and Review Technique (PERT) for the Navy's Polaris program. See Harvey M. Sapolsky, *The*

Polaris System Development, Bureaucratic and Programmatic Success in Government, (Cambridge, Mass.: Harvard University Press, 1972).

50. Memo to Gen. Schriever from Col. Terhune, subject: Continuous monitoring of USAF Atlas development contracts, Dec. 21, 1954, AFHRA Microfilm 35257. Memo to Gen. Schriever from Col. Sheppard, subject: WDD fiscal management w/ chart, Jan. 24, 1955, AFHRA Microfilm 35257. William A. Sheppard, the Deputy Commander for Program Management, to staff, subject: Contractor Supervision, Jan. 17, 55.
51. Ethel M. DeHaven, *AMC Participation in the AF Missiles Program through December 1957*, (Inglewood, Calif.: Office of Information Services, AMC Ballistic Missile Office, 1958), pp. 185-87.
52. Symposium on Guided Missile Reliability, Nov. 2, 3, 4, 1955, Sponsored by the Department of Defense, under auspices of Air Research and Development Command, AF-WP-O-21, September 1956, 56RDZ-12531, Wright-Patterson AFB, Ohio, AFHRA Microfilm 26254.
53. Maj. Ernst P. Luke, Mr. Ernst Lange, Holloman Air Development Center, "Weapon System Evaluation and Reliability," in Symposium on Guided Missile Reliability, Nov. 2, 3, 4, 1955, Sponsored by the Department of Defense, under auspices of Air Research and Development Command, AF-WP-O-21, Sep. 1956, 56RDZ-12531, Wright-Patterson AFB, Ohio, AFHRA Microfilm 26254, pp. 169-70.
54. Neufeld, *Ballistic Missiles*, pp. 178-79, 205-206. Atlas Program Information Prepared for Stennis Sub-Committee, May 20, 1961, AFHRA K243.012-42, section on "Reliability Program."
55. Neufeld, *Ballistic Missiles*, pp. 217-20. "Excerpts from Task Force's Report to Kennedy on U. S. Position in Space Race," *New York Times*, January 12, 1961. For details about Atlas failures, causes, and responses, see Problems of the Atlas Program: Status - Corrective Action, 26 April 1965, AFHRA Box "J6 and J7," no file # or name.
56. Neufeld, *Ballistic Missiles*, pp. 217-19.
57. Stanley and Weaver, *An Air Force Command for R&D*, p. 31. Gorn, *Vulcan's Forge*, pp. 53-56.
58. Gorn, *Vulcan's Forge*, p. 57. Howard R. Murphy, *History of the Air Force Command and Control Development Division, 16 November 1959-31 March 1961*, Vol. 1, Prolog to the Hanscom Complex, (Bedford, Mass.: Historical Division, Office of Information, Electronic Systems Division, Hanscom Field, Air Force Systems Command, 1964). pp. III-72 – III-73.
59. Gorn, *Vulcan's Forge*, pp. 59-61. Schriever, interview with author, Apr. 13, 1999.
60. Gorn, *Vulcan's Forge*, pp. 63-64. Murphy, *History of the AFCCDD*, pp. III-74 –III-75.
61. Gorn, *Vulcan's Forge*, pp. 63-69. Stanley and Weaver, *An Air Force Command for R&D*, pp. 34-37. The most detailed description of the entire Anderson Group effort is in Harry C. Jordan, *History of Ballistic Systems Division, Air Force Systems Command*, Historical Division, Office of Information, Ballistic Systems Division, AF Systems Command, Norton AFB, California, Apr. 3, 1963, MITRE Box 1753.
62. Schriever, interview with author, April 13, 1999. Gorn, *Vulcan's Forge*, p. 69. Stanley and Weaver, *An Air Force Command for R&D*, p. 37. Jordan, *History of Ballistic Systems Division*, p. 97.
63. Jordan, *History of Ballistic Systems Division*.
64. See Gorn, *Vulcan's Forge*, pp. 71-72. Stanley and Weaver, *An Air Force Command for R&D*, pp. 39-41. David N. Spires, *Beyond Horizons: A Half Century of Air Force Space Leadership*, (Washington, D.C.: U.S. Government Printing Office, 1997), pp. 86-92.
65. Gorn, *Vulcan's Forge*, p. 72. Stanley and Weaver, *An Air Force Command for R&D*, pp. 41, 44.
66. Neufeld, ed., *Reflections on R&D in the USAF*, p. 65.
67. Deborah Shapley, *Promise and Power; The Life and*

Times of Robert McNamara, (Boston: Little, Brown & Co., 1993).

68. C. W. Borklund, *The Department of Defense*, (New York: Frederick A. Praeger, 1968), pp. 70-71. Charles J. Hitch, *Decision-Making for Defense*, (Berkeley and Los Angeles: University of California Press, 1967), pp. 31-32. F. T. Moore, memo to Research Council, subj. "The 92 Labors of Secretary McNamara," Mar. 17, 1961, WM-663, Charles Babbage Institute 90, Burroughs Collection, System Development Corporation Series, Box 1, "RAND Corporation: Correspondence and Clippings," folder. McNamara initially instituted 92 projects, but these grew to over 100.
69. Col. Otto J. Glasser, USAF, Hq, AFSC, "Current AFSC Management Environment," ca. 1962, Library of Congress (LC), Samuel C. Phillips Papers, Box 19, p. 5-1-1.
70. *Ibid.*, p. 5-1-3.
71. Department of Defense Annual Report for Fiscal Year 1961, quoted from Glasser, p. 5-1-5.
72. Glasser, pp. 5-1-7, 5-1-8.
73. Stephen B. Johnson, "From Concurrency to Phased Planning, an Episode in the History of Systems Management," in Thomas P. Hughes and Agatha Hughes, eds., *Systems, Experts, and Computers*, (Chicago: University of Chicago Press, forthcoming).
74. Ltr, Gen. B. A. Schriever to Gen. C. E. LeMay, Apr. 30, 1962, LC, Samuel C. Phillips Papers, Box 19, p. 4.
75. Merton J. Peck, and Frederic M. Scherer, *The Weapons Acquisition Process: An Economic Analysis*, (Boston: Division of Research, Graduate School of Business Administration, Harvard University, 1962), pp. 19-24. Ants Kutzer, "Implementation of a Satellite Project," Paper presented on the occasion of leaving the European Space Technology Centre on 15 September 1967, Historical Archives of the European University Institute, Florence, Italy, Fond 51048, Table I.
76. Memo, Schriever to LeMay, subject: Systems Acquisition Management Improvement, February 5, 1962, LC, Samuel C. Phillips Paper, Box 19.
77. *Ibid.*, p. 1.
78. U.S. Air Force, Air Force Systems Command, *Rainbow Reporting: Systems Data Presentation and Reporting Procedures, Program Management Instruction 1-5*, Jan. 15, 1963, LC, Samuel C. Phillips Papers, Box 18.
79. *Ibid.*, p. 2. Special Projects Office, "Program Evaluation Research Task, Summary Report, Phase 1," Bureau of Naval Weapons, Department of the Navy, Washington DC, July 1958. It was later renamed Program Evaluation and Review Technique.
80. Schriever to LeMay, Feb. 5, 1962, p. 3.
81. U.S. Air Force, Air Force Systems Command, *A Summary of Lessons Learned from Air Force Management Surveys*, AFSCP 375-2, Jun. 1, 1963, LC, Samuel C. Phillips Papers, Box 36.
82. Memo, Maj. Gen. Robert J. Friedman, DCS/Comptroller, to distribution, subject: Guidance and Plan for Follow-Through on the Work of the Monterey Management Conference, Jun.12, 1962, LC, Samuel C. Phillips Papers, Box 19.
83. U.S. Air Force, Air Force Systems Command, *AFSC Management Objectives, FY 1964*, August 1963, LC, Samuel C. Phillips Papers, Box 18.
84. Schriever later noted that when McNamara took office, the days when he could "get things done" were over. He thought the bureaucracy removed flexibility and speed from the military. See Schriever, Interview with Puryear, p. 7. Neufeld, *Reflections on R&D in the USAF*.
85. DoD Directive 3200.9, "Initiation of Engineering and Operational System Development," Jul.1, 1965.
86. See Stephen B. Johnson, "Three Approaches to Big Technology: Operations Research, Systems Engineering, and Project Management," *Technology and Culture* 38:4 (Oct. 1997): 891-919.

USAF Logistics in



the Korean War



William W. Suit

(Overleaf) The Korean conflict saw a number of different kinds of earth-moving equipment used. (All photos courtesy of the author.)

NO COMBAT SORTIES COULD HAVE BEEN FLOWN WITHOUT THE SUPPORT OF THE LOGISTICAL TAIL

While the preponderance of air power history focuses on the planning and execution of combat missions, the vast majority of personnel who contributed to the U.S. Air Force's Korean War effort served in a support function, such as training, medical, intelligence, security, or communications. This article looks at logistics. Although the contributions of mechanics, civil engineers, and supply officers often went unnoticed, no combat sorties could have been flown without the support of the logistical tail that began at the war materiel production facilities and ended with the flight line support crews. Hopefully, the reader will gain an appreciation for the effort required to place fueled and armed combat aircraft into the skies over Korea.

North Korea's invasion of South Korea caught the U.S. and its Allies by surprise and minimally prepared for the ensuing air war. At first, the USAF, U.S. Navy, Royal Australian Air Force and Britain's Royal Navy scrambled to throw their available aircraft into the fight. During the first critical weeks, the USAF Far East Air Force (FEAF) contribution proved crucial in halting the North Korean onslaught, and throughout the war the FEAF continued to provide the bulk of the personnel, aircraft, and logistics that comprised United Nations (UN) air forces. As the war progressed, efforts to move tactical air units to Korea

were hampered by the paucity of adequate airfields, port facilities, and ground transportation in South Korea. Much of what did exist was damaged or destroyed during the first seven months of the war, as the warring armies and UN tactical air units moved up and down the peninsula. Accordingly, the Air Force, with Army assistance, repaired and upgraded the few airfields that existed, built additional runways, and established a logistics pipeline. All this was done as the FEAF competed for resources with an American-led and financed, European-centered, large-scale rearmament effort. Thus, even at the height of combat, the Air Force committed no more than one fourth of its rapidly expanding resources to FEAF, which included the Fifth Air Force (in Japan), Thirteenth Air Force (Philippines) and Twentieth Air Force (Okinawa and the Marianas).¹

The United States faced no military threat immediately following World War II. Accordingly, America rapidly demobilized, leaving mountains of air war materiel strewn about the globe and tens of thousands of aircraft stored around the country. At the same time that the Air Force was dismantling its stock of piston-engine aircraft, it was embarking on the development of a smaller atomic-jet air force. In 1947, the newly created Air Force numbered 339,000 military personnel and employed an additional 111,000 civilians, down

Airfield drainage excavation in Korea.



THE USAF FAR EAST AIR FORCE CONTRIBUTION PROVED CRITICAL IN HALTING THE NORTH KOREAN ONSLAUGHT

William W. Suit, is a historian at Headquarters Air Force Materiel Command, Wright-Patterson AFB, Ohio, and earned his Ph.D. from Kent State University. He has written and lectured in the fields of air power logistics and technology. Dr. Suit wrote a chapter on Persian Gulf War logistics for the Greenwood Press book, The Eagle in the Desert.



An RF-80C in Korea.

**THE
“FINLETTER
COMMISSION”
RECOM-
MENDED
THAT THE AIR
FORCE
ESTABLISH A
MINIMUM OF
SEVENTY
COMBAT
GROUPS**

**BY 1950, THE
LACK OF
FUNDS COM-
PELLED THE
AIR FORCE
TO SCALE
DOWN ITS
PROCURE-
MENT PRO-
GRAM TO
PROVIDE FOR
ONLY FORTY-
EIGHT
GROUPS**

from 2.3 million and 410,000, respectively, three years earlier. Aircraft on hand had fallen from a World War II high of 78,000 to 23,000 in 1947, and most of these were in storage.² From a logistics viewpoint, the USAF faced two primary tasks: culling the vast store of materiel left over from the war and equipping itself with modern aircraft and support equipment. The mass exodus of skilled support personnel from the Army Air Forces following the war and a precipitous drop in defense spending hampered these efforts.

The bulk of the materiel in Europe, mostly in the United Kingdom, had been declared surplus and sold for token sums. The situation in the Pacific was more complicated. At the beginning of the Korean War, vast stores of materiel remained scattered across the region, at locations such as Guam, the Philippines, Australia, New Guinea, and Japan. In the continental U.S. (CONUS), the USAF rapidly reduced its depot structure, but in 1950, Air Force warehouses still bulged with war surplus.³

The President’s Air Policy Commission—also called the “Finletter Commission”—and the Congressional Aviation Policy Board or the “Brewster Committee”—had recommended that the Air Force establish a minimum of seventy combat groups (or wings), equipped with new aircraft, to meet the nation’s security needs. By 1950, the lack of funds compelled the Air Force to scale down its procurement program to provide for only forty-eight groups. With the limited funding available and development-to-production lead times growing, an all-jet combat fleet appeared to be many years away.⁴

In June 1950, FEAF possessed approximately 1,200 aircraft, many not operational. Primarily organized and equipped as an air defense force, FEAF’s air fleet consisted of F-51 Mustang piston-engine fighters, F-80C jet fighters, F-82 Twin Mustangs, B-26 piston-engine light bombers, and B-29 bombers. The task of supplying the FEAF with the aircraft and war materiel required to

fight in Korea fell to Air Materiel Command (AMC), Far East Air Materiel Command (FEAMCOM), and the maintenance, supply and transportation units within the FEAF. Moreover, during the opening days of the war FEAF fought with the men and materiel on hand, because it took several weeks for supplies from the U.S. to reach Japan. After helping sweep the North Korean Air Force from the skies, the F-80Cs, the FEAF’s most numerous aircraft type, proved unsuited for the vital tasks of interdiction and close air support. The F-80Cs had a limited range, were not equipped to carry both bombs and external fuel tanks, were not equipped with pylon bomb racks, and could not operate easily from austere airfields in Korea. To meet the pressing need for ground attack aircraft during the early months of the war, FEAF stopped reassembling and overhauling incoming F-80Cs and began returning mothballed F-51s and B-26s to combat condition. Additional F-51s and B-26s soon began arriving from the U.S. and once the necessary parts were acquired, FEAMCOM began modifying F-80s to extend their range and increase their weapons load capacity.⁵

The USAF had been an independent service for only three years when the Korean War began and was in the process of developing the next generation of aircraft, weapons, and support equipment. Except for the dramatic decline in support activity, the basic USAF logistics function had changed little from that of the predecessor AAF. Air Materiel Command (AMC), commanded by Lt. Gen. Benjamin W. Chidlaw⁶, headquartered at Wright-Patterson AFB, Ohio, served as the primary logistics support organization for the Air Force. The command performed several major logistics functions: supply; maintenance, modification and repair; and materiel acquisition. AMC headquarters, through its subordinate regional procurement units, negotiated and managed major contracts for goods and services, including aircraft purchases and modification projects. The command operated a network of air materiel areas (AMAs) and specialized supply depots in the CONUS. The AMAs and depots housed supply warehouses and operated large industrial facilities for the overhaul, repair and modification of aircraft, spare parts and specialized equipment.⁷ The Sacramento AMA, located at McClellan AFB, California, was the focal point for materiel support to FEAF units. The Air Force also maintained two overseas depots, one at RAF Burtonwood, England, and one at FEAMCOM Air Base, Tachikawa, Japan. The Far East Air Materiel Command (FEAMCOM), a FEAF subordinate unit, commanded by Brig. Gen. John P. Doyle⁸, operated the air depot in Japan and served as the in-theater materiel support organization for FEAF. The Air Force utilized a three-tier system for aircraft and equipment maintenance—organization, field and depot. Under this system, a squadron’s ground crews conducted flight line inspections, preventive maintenance, and minor repairs. Field maintenance included repairs requiring fixed shops, spe-



BY NOVEMBER 1950, AMC DEPOTS AND PRIVATE CONTRACTORS HAD MODIFIED AND RECONDITIONED MORE THAN 400 MOTHBALLLED AIRCRAFT

MANY AIRCRAFT WERE EXPOSED TO CORROSIVE SEA AIR AND SALT-WATER SPRAY

THROUGHOUT THE WAR PARTIALLY DISASSEMBLED AIRCRAFT ARRIVED BY SHIP... AT YOKOHAMA, JAPAN

cialty skilled personnel, and heavy precision tooling and was performed at the air base level. Depot maintenance included aircraft, equipment and component overhaul and modifications performed at a CONUS AMA or at one of the overseas depots. Organizationally, the USAF employed a standard wing/base structure that assigned a maintenance group, a supply group, and an airdrome group (later renamed air base groups) to each wing or major base. The supply groups (or squadrons in some cases) in FEAF requisitioned supplies through FEAMCOM, which procured materiel from AMC and, where time critical or cost effective, from local suppliers. The U.S. Army Japan Logistics Command provided FEAF with common supplies such as boots, clothing and tents.⁹

Responsibility for inter-theater and intra-theater transportation was divided among several organizations. The Military Sea Transportation Service directed sealift activities between the CONUS, Japan, and Korea, utilizing both U.S. Navy and contractor vessels. The Military Air Transport Service (MATS) was responsible for airlift between the U.S. and Japan. MATS provided the bulk of the aircraft for this intercontinental air link, but augmented its own air fleet by contracting with commercial air carriers. The Combat Cargo Command—later renamed the 315th Air Division (Combat Cargo)—served as the in-theater air transport provider.¹⁰ Several allied air force transport units served under the 315th Air Division. The Theater Air Transport Board allocated the limited air cargo capacity available in the FEAF theater among the using services.¹¹ The U.S. Army's Military Railway Service supervised railroad operations in Korea, but South Korea's National Railway, under contract to the U.S. Army, ran the trains and accomplished much of the necessary repair work. The Japanese had originally built the Korean rail system and thus served as a source of replacement parts and equipment. The

U.S. Eighth Army provided most motor transport between the port facilities, supply depots, and Fifth Air Force units in Korea. The Army also utilized helicopters to deliver supplies and personnel to remote locations.¹²

Air Materiel Command responded to the sudden demand for aircraft, equipment, and supplies by first drawing heavily on World War II surplus. By November 1950, AMC depots and private contractors had modified and reconditioned more than 400 mothballed aircraft for FEAF and transferred an additional 275 aircraft from U.S.-based units. The Air Force preferred to transport fighter aircraft to Japan aboard Navy carriers.

Unfortunately, when shipped, many aircraft were secured to the upper decks of freighters and tankers, where they were exposed to corrosive sea air and salt-water spray. Covering the aircraft with grease and rubber coating cocoons limited, but did not eliminate, salt corrosion. The first 147 F-51s arrived in Japan aboard the carrier USS *Boxer* in late July 1950. The AMAs installed ferry fuel tanks on longer-range aircraft, such as B-26s and C-47s, which island-hopped to Japan.¹³ To meet Korean War and Mutual Defense Assistance Program (MDAP) materiel demands, the command rebuilt its procurement, maintenance, modification and supply organizations, and infrastructure. Existing supply and maintenance depots expanded operations, and several facilities that had closed after World War II were reactivated. Command personnel strength almost doubled, peaking at 192,000 in 1953.¹⁴ Aircraft procurement funding jumped from \$1 billion in 1950 to \$10 billion by 1952. American aircraft manufacturers responded by producing thousands of modern jet aircraft, both for the U.S. armed forces and for distribution to allies through the MDAP.¹⁵ Surplus stocks of ammunition and bombs provided an immediate supply source of certain types of munitions, but munitions manufacturers had to

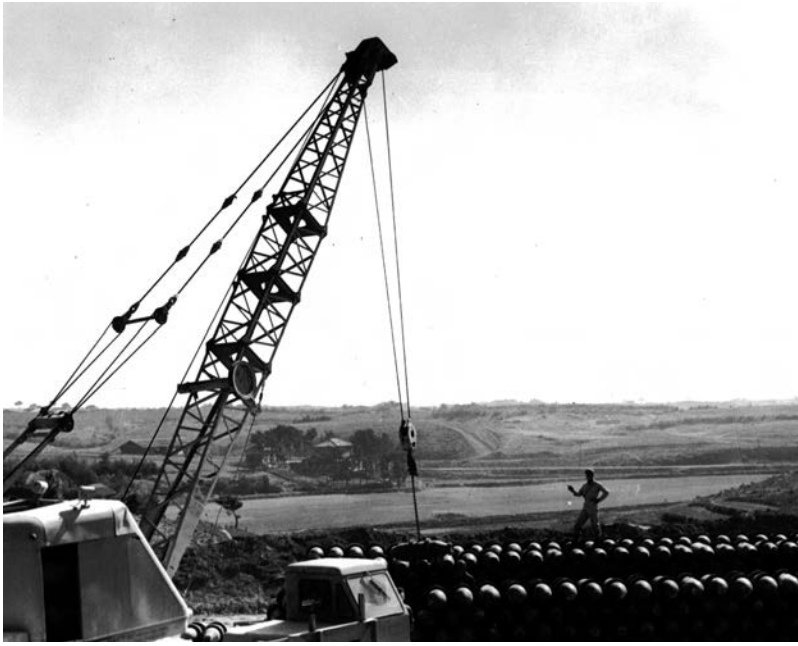

Open air bomb storage in Korea.

THEN THEY WERE LOADED ON BARGES FOR TRANSPORT ACROSS TOKYO BAY ...WHERE THEY WERE REASSEMBLED AND MADE COMBAT READY

increase rapidly the production of napalm tanks, phosphorous bombs, and ground-attack rockets to meet air armament requirements. Given time to organize, both AMC and its industrial partners were soon supplying both the USAF and its allies with substantial quantities of modern air war materiel.

FEAMCOM operated a major supply and maintenance depot at Tachikawa AB, Japan, on the site of a former aircraft company industrial facility. FEAMCOM also maintained an aircraft assembly base at Kisarazu AB, on Tokyo Bay; the Tama Arsenal near Tokyo; and the Yamada Reserve Aviation Ammunition (AVAMMO) depot on Kyushu.¹⁶ In June 1950, the main activity at the FEAF depot facility involved preparing F-80A and F-80B jet fighters for return to the CONUS and preparing recently-arrived F-80Cs for service with FEAF units converting from the older F-80s and F-51s to the newer jet fighter. Preparing new fighter, liaison, and forward air control (FAC) aircraft for Korean combat remained a major task throughout the war. Early 1950s fighter aircraft did not have the range to *island hop* across the Pacific; it was not until the end of the war that aerial-refueling capable fighters, F-84s, would make direct flights from the U.S. to Japan. Throughout the war partially disassembled aircraft arrived by ship and were unloaded at Yokohama, Japan. Then they were loaded on barges for transport across Tokyo Bay to Kisarazu, where they were reassembled and made combat ready. Almost all aircraft shipped to Japan suffered some degree of salt corrosion damage, which had to be repaired upon arrival.¹⁷

One of the major responsibilities of the Tachikawa depot involved installing the modifications and upgrades to improve the performance of FEAF aircraft or correct defects identified after the aircraft arrived in theater. Some of the modifications performed in Japan included replacing

C-119 tail booms; installing pylon bomb racks and increased fuel capacity wing tanks on F-80s; replacing F-86 leading edge wing slats; installing reconnaissance cameras on F-86s; and, toward the end of the war, modifying F-80s and F-84s for in-flight refueling. Upgrading in-theater aircraft to correct safety problems or to improve reliability and performance directly affected combat effectiveness. The most notable example involved replacing the wing leading edge slats on F-86Es and F-86Fs with extended solid leading edges. This relatively simple drag-reducing modification increased the F-86E's ceiling by 4,000 feet, increased high-speed maneuverability, and improved the aircraft's rate of climb. FEAMCOM's 13th Maintenance Group (MG) also performed airframe and equipment overhaul, minor engine overhaul (jet engines were returned to AMC depots for major overhauls) and battle damage repair. Much of FEAMCOM's specialized vehicle maintenance was done under contract by the Showa Aircraft Company, at a facility designated Area A of FEAMCOM AB. Showa Aircraft provided the labor, but FEAMCOM provided the equipment, because the equipment previously owned by both the Showa Aircraft Company and Tachikawa Aircraft Company had been confiscated as war reparations following World War II. The depot also modified ground equipment. For example, the 13th MG modified and installed photographic equipment in portable vans and trailers to provide operational bases with on-site photographic laboratory capabilities. It also modified over 100 Jeeps to carry twelve-channel VHF radios and generators for use by Tactical Air Control Party (TACP) ground crews. Utilizing these semi-mobile radios, TACPs worked closely with Army artillery units to provide air strike battlefield support. In addition, the 13th MG repair shops overhauled and repaired numerous components such as propellers, brakes, radios, and powered ground equipment.¹⁸

As FEAMCOM expanded its maintenance and modification activities, the command turned to the Japanese labor pool for skilled and relatively low-paid workers. The FEAMCOM (later renamed the Far East Air Force Logistics Force [FEALOGFOR]) work force eventually grew to over 6,300 Americans (both military and civilian) and 16,500 Japanese. Japanese seamstresses repaired flight clothing and parachutes, foundry workers produced castings that machinists fashioned into aircraft components, and sheet metal workers repaired the battle damaged skins of combat aircraft flown to Japan for repair. FEAMCOM also employed Japanese engineers, draftsmen, tool and die makers, supply managers, and many other skilled workers and laborers at its depot and munitions facilities.¹⁹

The lack of transportation, frequent relocations, and poor weather took a toll on aircraft operating from forward air bases in Korea. As has been observed, existing Air Force operational procedures required that field level maintenance be performed at the base or wing level. Theoretically, this



**DURING THE
FIRST YEAR
OF THE WAR,
...EQUIPMENT
OFTEN
FAILED TO
ARRIVE, ...
AND WHEN IT
DID, MAY NOT
HAVE BEEN
UNPACKED**

included groups and wings deployed to forward operating bases in combat zones. However, that system did not work well in Korea, because field level maintenance required the use of heavy support equipment and machines—2,000 short tons of supplies and equipment for a jet fighter wing and 2,700 short tons for a conventional light bomber wing. During the first year of the war, when the tactical wings were constantly on the move, the equipment often failed to arrive at the forward operating bases, and when it did, may not have been unpacked because the bases lacked hangars and structures to house the tools and equipment, or because the units relocated quickly. Not surprisingly, much equipment was abandoned, pilfered, lost or ruined by exposure to the weather. Until the fighting front stabilized, FEAF units in Korea rarely possessed enough building materials, supplies, spares, machinery or equipment to adequately establish the necessary supply systems and maintenance facilities to conduct effective field level maintenance. Acquiring sufficient spare parts for new types of aircraft, such as the various F-84 and F-86 models, proved particularly difficult.

Because the new aircraft types had accumulated limited service time, and the operating conditions in Korea were unusually severe, AMC and the manufacturers could not accurately predict spares requirements based on past consumption. As a result, the depots quickly depleted their stocks of particular items and the manufacturers had to rush production, often shipping the items directly to FEAMCOM. A case in point involved the bulky and expensive F-86 external wing tanks. These tanks were originally designed as ferry tanks with the expectation that they were reusable items. The Air Force, therefore, acquired only a limited stock. However, F-86s had to carry the tanks to reach MiG Alley near the North

Korean-Chinese border, and the pilots had to jettison the tanks prior to engaging the MiG-15s. Inevitably, the stock of external tanks vanished, and during January and February 1952, the 4th Fighter Wing (FW) and the 51st FW had to curtail F-86 combat operations. Fortunately, production eventually caught up with consumption. Also, few airfields possessed adequate hangars, forcing many ground crews to perform maintenance outside, with only rudimentary windbreaks as shelters against the winter weather. Thus, forward-deployed aircraft received just enough maintenance and repair to keep them flying, and aircraft combat readiness rates declined rapidly.²⁰

Fifth Air Force flying units learned to alleviate the poor maintenance support situation at the air bases in Korea by locating their heavy field maintenance equipment at a secure rear area base in Japan, and periodically flying their aircraft back to the equipment for intermediate and major inspection and repair.²¹ The experiences of the 27th Fighter Escort Wing and the 49th Fighter-Bomber Wing provided an example of the practicality of this arrangement. The 49th Wing moved to Taegu in October 1950, where it attempted to perform field level maintenance on its F-80s in harsh weather without adequate shelter or equipment. The wing sent ten F-80s back to the FEAMCOM depot in March 1951 for inspection and repair, where inspection found the aircraft in such poor condition that they required an average of 7,500 man-hours to recondition each plane. By comparison, the 27th Wing moved to Taegu in December 1951, but left its intermediate and major maintenance assets at Itazuke AB. By shuttling its F-84s back to Japan for intermediate and major inspection and repair, the 27th Wing managed to keep forty-eight F-84s in commission at Taegu at all times and none of its aircraft deteriorated as badly as had the 49th Wing's F-80s. The disparity in



Rolling the asphalt.

TRANSPORTS AND MEDIUM BOMBER UNITS EXPERIENCED MANY LOGISTICS DIFFICULTIES SIMILAR TO THOSE OF THE FIGHTERS AND LIGHT BOMBERS

THE BULK OF THE TRANSPORT AIRCRAFT OPERATED FROM THE RELATIVE COMFORT OF JAPAN

maintenance results caught the attention of Fifth Air Force logisticians. Similar positive results occurred when the 452d Bombardment Wing moved to Pusan East (K-9) in May 1951, but left its major maintenance capability at Miho AB, Japan. The 3d Bombardment Wing moved its entire maintenance capability to Kunsan in August 1951. Both flew B-26s. From July through December 1951, the 3d Wing's in-commission rate dropped from 78 to 65 percent and its monthly flying hours dropped from 5,425 to 3,904. Whereas for the same period, the 452d's in-commission rates rose from 57 to 82 percent and its flying hours per month from 3,884 to 4,612. The Fifth Air Force soon realized that the aircraft receiving rear area maintenance maintained higher in-commission rates, suffered fewer accidents and mission cancellations, and completed more flying hours than aircraft receiving forward based field maintenance. Consequently, FEAf established Rear Echelon Maintenance Combined Operation (REMCO) operations at air bases in Japan for most Korean-based fighter and fighter-bomber units. REMCOs combined the field maintenance activity for two or more wings at a single base. In this way the wings could divide base support, supply, and maintenance responsibilities, thus reducing manpower and equipment requirements. REMCOs performed all major inspections on aircraft and accomplished all field level maintenance, including minor engine repair, battle damage repair and technical order compliance modifications. Maintenance crews organized aircraft and engine maintenance production lines to better exploit available hangar space, machinery and skilled technicians.²² Free from the need to perform field maintenance, forward based maintenance units performed only organizational maintenance, such as, preflight and post-flight inspections, servicing and aircraft arming, emergency engine replacements, and one-time

flight repairs. The Fifth Air Force established REMCO facilities for F-80s at Tsuiki (then F-86s in January 1952), for F-84s at Itazuke, and for B-26s at Miho.²³

Transports and medium bomber units experienced many logistics difficulties similar to those of the fighters and light bombers. Fortunately for the maintenance crews, the bulk of the transport aircraft operated from the relative comfort of Japan and all of the B-29s operated from Okinawa, Guam, or the Japanese main islands. The 315th Air Division's three Troop Carrier Wings (TCW) were headquartered in Japan, at Tachikawa, Ashiya, and Brady. Troop carrier detachments eventually operated from six additional bases in Japan and eight in Korea. The 315th experienced serious maintenance difficulties with the relatively new C-119s and the new C-124s, that were rushed to Korea without sufficient spares or trained repair personnel.

The 403d TCW, operating C-119s from Ashiya, serves as a case in point. Two factors contributed to the near cessation of C-119 operations in the summer of 1952. First, the C-119s were not designed to operate from rough fields, but nonetheless, early in the war continuously flew heavily-laden into and out of crude forward area strips where the aircraft were literally shaken apart. Second, the 403d received abysmal spares support and inadequate theater maintenance. As a result, during June and July 1952, the wing managed to keep between 23 and 28 of its 71 active C-119s in commission. The problem was alleviated only after AMC established an emergency spares replenishment program, and the war weary C-119s were rotated out and replaced with newer aircraft. By June 1953, the 403d Wing's C-119 in-commission rate had climbed to 78.8 percent.²⁴

Even with the accompanying maintenance difficulties, moving aircraft units as close as possible to the fighting front greatly increased their combat efficiency. Fortunately, the USAF quickly cleared the South Korean skies of enemy aircraft. This allowed the Fifth Air Force to establish forward operating air bases in South Korea, free from the threat of air attack. Concurrently, FEAf moved as many tactical air units as space would allow to existing airfields on Kyushu, to place the aircraft as close as possible to Korea. From these Japanese and Korean bases, the fighters and light bombers could range farther north, while carrying more bombs and less fuel. However, geography and the very limited transportation infrastructure in South Korea conspired to place major obstacles in the way of all UN military forces trying to rush personnel and materiel into Korea. South Korea possessed only one high-capacity, deep-water seaport, Pusan, and one other large seaport capable of handling coaster-sized ships, Inchon.

When Inchon was liberated in September 1950, two main rail lines (one double- and one single-track) connected Pusan and Seoul via different routes. A rail line and a highway connected Inchon and Seoul. The mountains that ran north and

INITIALLY, THE NORTH KOREAN TRANSPORTATION INFRASTRUCTURE WAS SUPERIOR TO THAT OF THE SOUTH..., HOWEVER, MOST OF THE NORTH'S ... FACILITIES, AND AIRFIELDS WERE BADLY DAMAGED BY FEAF AIR INTERDICTION ATTACKS

THE GREATEST OBSTACLE TO OPERATIONS FACED BY TACTICAL AIR UNITS DURING THE FIRST TWO YEARS OF THE WAR WAS THE LACK OF ADEQUATE SECURE AIR BASES IN KOREA



south along the length of the peninsula dictated that the rail lines follow circuitous routes with numerous steep grades, bridges and tunnels, thus limiting the capacity of the freight each train could carry. Paved roads outside of the few major cities were virtually non-existent, restricting the movement of supplies by truck. Rice fields covered most of the flat lowlands and terraced the river valleys. These fields were flooded during the summer growing season. Furthermore, at least initially, the North Korean transportation infrastructure was superior to that of the South. As the war intensified, however, most of the North's railroad marshalling yards, bridges, seaport facilities, and airfields were badly damaged by FEAF air interdiction attacks prior to and during the breakout from the Pusan Perimeter, and had to be repaired as the UN forces swept north. The cold, snowy Korean winters complicated any in-country movement and slowed all forms of transportation.²⁵

The situation for logistics personnel in Korea proved extremely difficult. The first Fifth Air Force flying units to arrive in Korea lacked the necessary support personnel and equipment to sustain combat operations. To meet immediate maintenance, supply, and munitions support needs, FEAMCOM established the Korea Air Materiel Unit (KAMU) at Taegu, South Korea, as a temporary forward based organization to augment the 6131st Tactical Support Wing. KAMU consisted of two field maintenance units, three depot support units and one ammunition supply squadron. These units dispersed to various Korean airfields, changing locations about once a month for the first six months of the war, and performed diverse support functions as necessary. For example, the 6401st FMU first deployed to Pohang (K-3),²⁶ where it accomplished aircraft battle damage repair and salvage work for the 6131st Tactical Support Wing, then returned to Japan, moved to Kimpo (K-14)

after the Incheon landing, and then moved to Pusan (K-1). The 6408th Depot Support Unit activated in September 1950, and moved to Suwon Air Base (K-13) where its personnel operated an ammunition dump, built roads, drove ammunition trucks and mixed napalm. In October the unit moved to Kimpo, then moved to Pyongyang (K-24) the next month, evacuated to Seoul Municipal Airport (K-16) by early December, then moved to Chinhae (K-10) to support the 18th Fighter Bomber Wing. The 543rd Ammunition Supply Squadron arrived at Pusan in September 1950, where its personnel began construction of a pierced steel planking reclamation facility, built revetments and provided guards in addition to constructing and operating an ammunition dump. The KAMU units deactivated after the battle lines stabilized, and their personnel returned to Japan. These units advanced and retreated with the fighter wings and fighter-bomber wings they supported. Their contributions filled an initial logistical support void in Fifth Air Force's tactical organization that would have otherwise severely limited the operational capability of the combat wings.²⁷

The greatest obstacle to operations faced by tactical air units during the first two years of the war was the lack of adequate secure air bases in Korea. Kimpo Airfield, just northwest of Seoul, was the only modern airfield in South Korea when the war began. Unfortunately, the North Koreans quickly captured Kimpo. In response, FEAF heavily damaged its two runways and support structures during air attacks. Only a few other airfields existed in South Korea. Most of these were built by the Japanese during World War II for use by light aircraft and had fallen into disrepair. Although USAF had rushed all of its engineer aviation units to Korea, they proved too few and poorly equipped. Also, the rapid movement that marked the first year of the war kept the heavy construction units

Laying pierced-steel planking over an oiled surface.



THE TASK OF REPAIRING AND EXPANDING EXISTING AIRFIELDS AND BUILDING NEW ONES FELL TO THE ENGINEER AVIATION UNITS

FEAF CONCENTRATED ON IMPROVING EXISTING RUNWAYS, BUILDING NEW RUNWAYS, AND BUILDING SUPPORT STRUCTURES

and their equipment on the move and, therefore, only able to accomplish the minimum work necessary to sustain combat operations at the growing number of airfields.²⁸

Responsibility for airfield construction and maintenance was divided among several military organizations. Though each type of unit was charged with specific responsibilities, civil engineering projects were completed by the organizations that possessed the necessary personnel and equipment. The task of repairing and expanding existing airfields and building new ones fell to the engineer aviation units. These were Special Category Army Personnel with Air Force (SCAR-WAF) organizations. As with other military organizations rushed to service in Korea, these hybrid Army-Air Force units lacked sufficient trained personnel and equipment.

In the summer of 1950, the most pressing task involved rebuilding and upgrading the only three Korean airfields that had not yet fallen into enemy hands—Pusan, Taegu, and Pohang. At Pusan, the 802d Engineer Aviation Battalion (EAB) found the concrete runway crumbling under the weight of transport aircraft, but nonetheless serviceable. Therefore, the 802d EAB departed for Pohang, leaving behind a small detachment to repair and keep open the runway. At Pohang, the 802d EAB added a 500-foot pierced steel planking (PSP) extension to the existing concrete runway, built hard stands, added a PSP apron, and built a cross taxiway. The engineers evacuated on August 13, 1950, as North Korean forces entered the area. The 822d EAB and the 919th Engineer Aviation Maintenance Company (EAMC) arrived at Taegu in late July and immediately laid down a PSP runway for use, while they resurfaced the existing hard clay runway. On August 16, 1950, enemy troops advanced close to Taegu forcing engineers to evacuate. However, a small contingent of the

919th EAMC remained to support aircraft that continued to stage through the airstrip.

Beginning in September, following the UN's amphibious landing at Inchon and the subsequent rout of the North Korean Army, tactical fighter and bomber units moved into a string of airfields ranging as far north as Yonpo, North Korea (K-27). The advancing tactical air units brought along as much engineering, maintenance, and supply capability as time and transportation allowed, but competition with the Army for scarce transportation capacity seriously limited the amount of heavy equipment reaching the advanced bases. When the Chinese counterattacked in December 1950, the forward-based tactical air units retreated South with the UN armies. Because they neither had enough time nor equipment to establish extensive support facilities, the retreating air units abandoned a relatively small amount of supplies and equipment. However, much equipment was lost in the overall confusion. Once the battle line stabilized near the 38th parallel, the FEAF concentrated on improving existing runways, building new runways, and building support structures at air bases in South Korea to support jet aircraft and heavy transports. Up to this point, no effort had been made to accomplish anything more than temporary repairs and improvements to existing airfields or to carve out simple landing strips for use as ground troop supply points or for use by liaison aircraft. Consequently, many major air base construction projects continued up to and beyond the cease-fire, and components of the three engineer aviation groups in Korea remained attached to each major base until the end of war.²⁹

Runway and support structure construction followed a similar pattern at almost all airfields in South Korea. The one exception was at Osan-ni (K-55), which was built from the ground up following

ENGINEER AVIATION UNITS WOULD ARRIVE AT AN AIRFIELD, FILL IN BOMB CRATERS WHEN NECESSARY, THEN LAY DOWN PSP SURFACES

USAF INSTALLATIONS SQUADRONS WERE SUPPOSED TO ASSUME RESPONSIBILITY FOR RUNWAY UPKEEP, BASE ENGINEERING SUPPORT, AND FACILITY IMPROVEMENTS

THE AIR FORCE RELIED ON THE NAVY FOR ITS SUPPLY OF 5-INCH HIGH VELOCITY AERIAL ROCKETS

a master plan. Most often, engineer aviation units would arrive at an airfield, fill in bomb craters when necessary, then lay down PSP surfaces and extensions. Other support units or local laborers would concurrently erect temporary tent housing and crude maintenance shelters. As heavy construction equipment became available, the engineers enlisted local labor to help construct asphalt runways. This pattern held true from the initial deployment to South Korea through the advance to the Yalu River and the retreat back to the 38th parallel. After the fighting front stabilized, engineer aviation groups and installations squadrons concentrated on expanding and improving the airfields. For example, units of the 931st Engineer Aviation Group, which arrived in Korea in April 1951, spent the spring and summer of 1951 constructing runways at Kimpo (K-14), Pyongtaek (K-6) and Kunsan (K-8), and building the basic infrastructure—roads, sewers, drainage, water, fuel tanks, hangars, and housing—required by an operational air base at Suwon (K-13).³⁰ The Fifth Air Force also maintained over a dozen rough airstrips for Army resupply and liaison, and one restricted to F-51 operations. At these locations, sod, gravel, or beach sand runways sufficed. By July 1953, FEAF counted thirty operational airfields in Korea and dozens more in Japan, Guam, and Okinawa.³¹ In addition to runways, the engineers also built roads, aircraft fuel facilities, revetments, water distribution systems, drainage systems, electrical systems, and ammunition storage facilities. Because almost all airfields in South Korea were constructed in areas with high water tables, maintaining adequate drainage systems was imperative to avoid flooding and runway foundation erosion.³²

Once the engineering aviation units completed the initial heavy construction at a combat zone airfield, USAF installations squadrons were supposed to assume responsibility for runway upkeep, base engineering support, and facility improvements. However, engineering aviation units continued to be attached to the major air bases and remained involved in heavy construction and maintenance for the duration of the war. As a result, the installations squadrons very often worked with the engineering aviation units rather than replace them. Installations squadron support activities changed with the three phases of the war. FEAF first rushed small installations squadron detachments to the crude Korean airfields to support staging operations for tactical aircraft flying out of Japan. After the engineer aviation units completed necessary heavy construction and repair and moved on, some elements of the installations squadrons remained to continue to provide fire fighting and base engineering support, while other elements moved North to newly captured airfields to support staging operations. Following the retreat from North Korea, and stabilization of the fighting front, the installations squadrons concentrated on sustaining maximum operations at the airfields in South Korea. During

the early months of the war, the installations squadrons lacked the heavy equipment and personnel to accomplish necessary runway repairs and construction. They turned to local contract labor, who used simple hand tools to repair and extend runway surfaces, dig drainage networks, build sandbag revetments, and erect tents. At first, runways were lighted by portable lighting systems powered by small portable generators. As FEAF concentrated more air units in South Korea, and the necessary equipment and building materials became available, the installations squadrons turned to building support structures; establishing base-wide electrical systems; improving runway lighting; and constructing fuel storage and distribution facilities. For all of these tasks, the installations squadrons relied heavily on local contractors to supply laborers, plumbers, carpenters, electricians, draftsmen, firefighters and other craftsmen. The installations squadrons were also pressed into service constructing off-base roads (normally an Army responsibility) to connect outlying sites housing SHORAN beacon units, aircraft control and warning squadrons, and radio relay detachments. Once the buildings, pipelines, electrical systems, and roads were built, the installations squadrons kept them in working order.³³

Keeping the forward-based units supplied involved filling a supply line that usually stretched back to the CONUS. The three items required in the greatest bulk quantities by FEAF flying units were aviation fuel, munitions, and PSP. Fuels and lubricants represented over 60 percent of the tonnage of all materiel shipped to Korea. Fuel was transported in tanker ships from CONUS refineries as well as from the Middle East. By 1950, FEAF had established a relatively efficient fuel distribution system in Japan, but no such system existed in Korea. At first, the only means to transport fuel to forward operating bases was to off load fuel drums at Pusan, or later at Inchon, and deliver the fuel by truck. At an operational base, the fuel had to be transferred from drums to aircraft refueling units. When absolutely necessary, fuel drums could be airlifted aboard cargo aircraft, but air transport proved inefficient. As more transportation and construction engineering personnel arrived in Korea, the Army began transporting fuel in bulk by rail car, and eventually the Eighth Army 82d Engineer Petroleum Company began operating a fuel pipeline between Inchon and Seoul. By late 1952, the main air bases had adequate fuel storage and distribution facilities. The Air Force used four types of fuel: JP-1 or JP-4 for jet aircraft,³⁴ 100/130 octane aviation gasoline for piston-engine aircraft, 87 octane gasoline for gasoline engine vehicles and ground support equipment, and diesel fuel for some trucks, heaters and heavy equipment. The bulk of fuel consumed by the Air Force was JP-4 and high-octane gasoline. Large quantities of gasoline were also used to make napalm, which was mixed on-site at the tactical air unit operational bases.³⁵

FEAF expended a tremendous amount of muni-



Repairing a pierced-steel planking runway.

**JAPAN
PROVED TO
BE A
WELCOME
SOURCE OF
LOCAL MANU-
FACTURE,
REPAIR, AND
SKILLED
LABOR**

tions during the war, including 386,000 tons of bombs, 32,000 tons of napalm, 313,000 rockets, and 166 million rounds of .50 caliber ammunition.³⁶ Surplus World War II stocks provided a ready supply of bombs and .50 caliber ammunition, and fortunately a substantial amount was still in storage on Guam and Okinawa. No large stock of napalm tanks existed. To meet the emergency requirement for napalm tanks, AMC modified the standard F-80 75-gallon external wing-tip fuel tank to produce a 110-gallon napalm bomb. FEAMCOM arranged for Japanese firms to manufacture the tanks.³⁷ The Air Force relied on the Navy for its supply of 5-inch high velocity aerial rockets (HVAR). An adequate supply of HVARs existed in the U.S. to meet both initial FEAF and Navy needs, and American contractors soon increased production to meet additional demand. During the early weeks of the war, MATS cargo aircraft flew emergency shipments of HVARs to Japan.³⁸ However, airlifting bombs and rockets, even in-theater, was avoided if possible. The Military Sea Transportation Service carried almost all munitions from the U.S. to Korea. Trucks and rail provided land transport to the munitions depots and operational bases. FEAMCOM operated two large munitions supply dumps in Japan. In addition, the 546th Ammunition Supply Squadron maintained a facility on Okinawa, and the 13th Ammunition Supply Squadron maintained a facility on Guam. In September 1950, the 543d Ammunition Supply Squadron moved to Pusan AB and established a receiving, storage, and distribution dump to support Korean-based air units.³⁹

The rapid construction of airfields in Korea, and expansion of those in Japan, could most easily be accomplished using PSP. However, PSP was very heavy, bulky and in short supply. FEAMCOM scoured the theater for all the PSP available and requisitioned more from the CONUS. Still, engi-

neer and installation units in Korea could not get enough to meet all new construction needs. In addition, the jet aircraft and heavy transports quickly bent and warped the PSP, forcing the installation squadrons to constantly replace damaged sections. To help meet the need, FEAMCOM established two PSP reconditioning plants, one in South Korea and one at its depot in Japan. The plants first repaired the 60,000 used sheets located in theater and then remained in operation to recondition damaged planks as they accumulated. Located nearest to the bulk of the PSP runways, the Korean plant operated at a much higher capacity than the Japanese facility.⁴⁰

Both construction and aircraft support required large numbers of specialized vehicles and machines, including bulldozers, graders, fuel trucks, fire trucks, dump trucks, rock crushers, refrigeration units, water pumps, and electrical test equipment. Some medium duty trucks were purchased in Japan, but everything else had to be shipped from existing stocks at FEAF air bases, or from the U.S. Initially, almost all vehicles and equipment were drawn from World War II surplus. However, as old equipment wore out and as the number of jet aircraft and new transports in-theater increased, new support equipment and vehicles flowed into Korea. Some equipment and spares came directly from the assembly line to Korea.⁴¹

Fortunately for the U.S., Japan proved to be a welcome source of local manufacture, repair, and skilled labor. During the occupation of Japan, responsibility for all FEAF local purchase rested with FEAMCOM. This system of centralized control worked well when the Air Force relied very little on the local economy. However, when the war began, both the U.S. sources of supply—up to ten thousand miles away—and transportation links to FEAF bases became overwhelmed. Accordingly, AMC urged FEAMCOM to procure as much as it could locally. In response, FEAF decentralized purchasing authority to the base level to enable local commanders to contract for base-level goods and services. This allowed the newly established FEAMCOM Procurement and Industrial Planning Directorate to concentrate on acquiring combat critical materiel. The first major item procured in Japan was napalm tanks. With this production contract and later contracts, Japanese manufacturers initially experienced problems maintaining both high quality and high rates of production. These problems were eventually overcome, and FEAMCOM poured millions of dollars into the Japanese economy for the purchase of such items as jettisonable fuel tanks, radio transmitters and receivers, napalm bomb igniters, and tools. In addition to supplying items necessary to support the forces engaged in Korea, Japan soon became a source of off-shore procurement for the Military Defense Assistance Program.

The Korean War served as an immediate catalyst for the expansion and modernization of the

THE WAR STOKED FEARS IN WASHINGTON AND EUROPE THAT THE SOVIET UNION MIGHT INITIATE A CONFLICT IN EUROPE

U.S. Air Force. Following World War II, as the military rapidly demobilized, the AAF's skilled personnel, both military and civilian, returned en masse to private industry, and private industry reverted to a peacetime economy. The result was a huge surplus of war materiel at home and scattered around the Pacific, excessive infrastructure in the U.S., dwindling budgets, and a lack of skilled personnel at all levels. When the Korea War broke out, the USAF was able to draw on available resources to stem the tide of the enemy onslaught and then to support the FEAF units operating from established air bases and primitive Korean airfields. China's entry into the war

forced the USAF to build a string of permanent air bases in South Korea, commit large numbers of modern jet aircraft to combat, vastly improve Korea's transportation infrastructure, and establish the necessary logistics pipeline to support the air war. Concurrently, the war stoked fears in Washington and Europe that the Soviet Union might initiate a conflict in Europe. In response, the U.S. embarked on a major rearmament program for itself and its allies and established a string of air bases around the globe. Although the Korean War is now a distant memory and the Cold War is over, the U.S. still maintains a steady vigil in South Korea.⁴² ■

NOTES

1. A contemporary overview of USAF logistics support during the Korean War is provided in Maj. Gen. Paul E. Ruestow, Comdr FEAF/LF, "Air Force Logistics in the Theater of Operations," *Air University Quarterly Review* (Summer 1953): 46-56. The most recent coverage of USAF Korean War logistics is Beth F. Scott *et al.*, "The Logistics of War: A Historical Perspective," Air Force Logistics Management Agency, Gunter Annex, Ala., Aug 1, 2000.
2. *United States Air Force Statistical Digest 1947*, Dir. of Stat. Svcs., Compt., HQ USAF, Washington, D.C., 1948, pp. 15-16, 72, 132, 134. Air Force-produced studies are available at the Air Force Historical Research Agency (AFHRA), Maxwell AFB, Ala.
3. Air Force surplus property disposal efforts between World War II and the Korean War are described in E. Clifford Snyder, "History of USAF Supply Programs and Problems (1945-1949)," Hist. Office, HQ AMC (AMC/HO), W-PAFB, Ohio, Nov. 1950, pp. 21-118; Sarah A. Zimmerman, "History of USAF Packaging and Deterioration Control 1942-1952," AMC/HO, Apr. 1953, pp. 53-82; and Dorothy Miller, "USAF Surplus Property Disposal 1 Jul 49 - 30 June 1950," AMC/HO, Sep. 1951.
4. The Five Year Aircraft Procurement Program is described in Mary R. Self, "History of the Five Year Aircraft Procurement Program (1 January 1948 - 1 July 1949)," AMC/HO, Dec. 1949; Ethel M. DeHaven, "History of the USAF Five Year Aircraft Procurement Program 1 July 1949 - 31 December 1949," AMC/HO, Sep. 1950; Ethel M. DeHaven, "History of the USAF Five-Year Aircraft Procurement Program 1 January—30 June 1950," AMC/HO, Aug. 52. Also see "Survival in the Air Age," Report by the President's Air Policy Commission, Government Printing Office, Washington, D.C., Jan. 1, 1948; and Report of the Board of Officers to the Chief of Staff, USAF, Recommending General Policy and Air Force Action Regarding the President's Air Policy Commission Report and the Congressional Aviation Policy Board Report, HQ USAF, Mar. 23, 1948. Excerpts relevant to USAF aircraft procurement from Sen. Rpr. 949, Report of the Congressional Aviation Policy Board, National Aviation Policy, 80th Cong., 2d Sess. are included as a supporting document in Self, "History of the Five Year Aircraft Procurement Program." In July 1950, the USAF's combat strength consisted primarily of a little over 2,000 B-29s and B-50s, 96 jet-powered B-45s, 79 B-36s, approximately 2,000 first-line jet fighters (F-80s, F-84s and F-86s), 81 F-82 piston-engine Twin Mustangs, 3,500 second-line fighters (mostly propeller-driven F-47s and F-51s) and 1,200 second-line medium bombers (B-25s and B-26s). Aircraft figures are from *United States Air Force Statistical Digest*, Nov. 1952, pp. 162-64.
5. "History of FEAMCOM January to June 1950," p. 172.

- Very soon after the fighting began in Korea, AMC initiated Project HOLD-OFF, a crash effort to withdraw mothballed aircraft from storage and return them to operational condition. See Dorothy W. Trester, "History of the AF Storage and Withdrawal Program (1945-1952)," AMC/HO, Apr. 1954, pp. 1-88.
6. Chidlaw was succeeded by Gen. Edwin W. Rawlings in Aug. 1951.
7. The entire Aug. 4, 1952 issue of *Aviation Week* is dedicated to a very detailed examination of AMC.
8. Doyle was succeeded by Maj. Gen. Paul E. Ruestow in Jun. 1952.
9. For a description of AMC and FEAMCOM on the eve of the Korean War see Frederick A. Alling, *et al.*, AMC Historical Study Number 291, "History of the Air Materiel Command 1 January - 30 June 1950," AMC/HO, Oct. 1950; and Theodore A. Faulkner, *et al.*, "History of FEAMCOM January to June 1950," FEAMCOM/HO, Tachikawa, Japan, Sep. 1 1950, microfilm copy AFHRA roll number A7367. AMC Korean War supply efforts are briefly described in Dorothy L. Miller, "History of Supply of Overseas Air Forces 1947-1954," AMC/HO, Jun. 1953, pp. 9-21.
10. For a description of Combat Cargo Korean War activities see Annis G. Thompson, *The Greatest Airlift: The Story of Combat Cargo* (Tokyo: Dai Nippon Printing Company, 1954).
11. Ruestow, "Air Force Logistics in the Theater of Operations," p. 33.
12. U.S. Army Korean War logistics activities are described in John G. Westover, *Combat Support in Korea*, U.S. Army in Action Series, Washington, D.C.: GPO, 1987; and James A. Huston, *The Sineus of War: 1775-1953*, Army Historical Series, Washington, D.C.: GPO, 1966, pp. 615-52. Also see Roy E. Appleman, *South to the Naktong, North to the Yalu (June—November 1950)*, United States Army in the Korean War Series, Washington, D.C.: GPO, 1961), pp. 260-61.
13. AMC's initial response to the war are described in Frederick A. Alling, *et al.*, "History of Air Materiel Command Support of the Far East Air Force in the Korean Conflict," AMC/HO, Dec 50.
14. For a comprehensive account of AMC during the war see Frederick A. Alling, *et al.*, "History of Air Materiel Command 1 January-30 June 1951," AMC/HO, Nov. 51; Helen B. Joiner, "History of Air Materiel Command 1 July-31 December 1951," AMC/HO, Jul. 52; Ethel M. DeHaven *et al.*, "History of Air Materiel Command 1 January-30 June 1952," AMC/HO; "History of the Air Materiel Command 1 July-31 December 1952," AMC/HO; and Doris A. Baker, "History of Air Materiel Command 1 January-30 June 1953, AMC/HO.

15. The early 1950s aircraft build-up and initial distribution of air materiel through the MDAP are described in E. Clifford Snyder, "History of Production Problems During the Air Force Build-Up 1950-1954," AMC/HO; Mauer Mauer, "History of USAF Activities in Support of the Mutual Defense Assistance Program, Part I-To 1 July 1950," AMC/HO, Apr. 1951; Mauer Mauer, "History of USAF Activities in Support of the Mutual Defense Assistance Program, Part II - 1 July to 31 December 1950," AMC/HO, Nov. 1951; and Mauer Mauer, "History of USAF Activities in Support of the Mutual Defense Assistance Program, Part III-1 January to 30 June 1951," AMC/HO, May 1952.
16. FEAMCOM's mission and organization are described in "FEAMCOM Mission," HQ FEAMCOM, FEAMCOM AB, ca. 1952; "FEAMCOM," *Air University Quarterly Review* (Summer, 1951): 76-82, and Calvin J. Romrell, Capt. USAF, "The Logistics Planning Process of the Far East Air Materiel Command During the Korean War," (M.A. thesis, Air Force Institute of Technology, 1988).
17. 13th Maintenance Group activities are described in "History of FEAMCOM 1 Jul-31 Dec 50," FEAMCOM/HO, Tachikawa, Japan, ca. 1951, (AFHRA microfilm copy, roll K7413), pp. 199-247.
18. "History of FEAMCOM 1 January 1951-30 June 1951," FEAMCOM/HO, Tachikawa, Japan, ca. 1951, (AFHRA microfilm copy, roll K7415), pp. 125, 142-167; "History of FEAMCOM 1 July 1951-31 December 1951," FEAMCOM/HO, Tachikawa, Japan, ca. 1952, (AFHRA microfilm copy, roll K7416), pp. 90-97. FEAMCOM depot activity is also described in "Historical Report for January 1952," to CG, FEAMC, HQ 6400th Air Depot Wing, APO 323, Jan. 1952, (AFHRA microfilm copy, roll PO 300); and "History, 6400th Air Depot Wing February-June 1952," HQ 6400th Air Depot Wing, APO 323, Jun. 1952 (AFHRA microfilm copy, roll PO 300).
19. "FEALOGFOR and Japanese Labor," *Air University Quarterly Review* (Summer 1953): 93-97. Also see "History, 6400th Air Depot Wing."
20. FEAF aircraft maintenance is discussed in detail in James I. Forney, Capt. USAF, "Logistics of Aircraft Maintenance During the Korean War," (M.A. thesis, Air Force Institute of Technology, 1988). Logistics difficulties are examined USAF Historical Study No. 72, "United States Air Force Operations in the Korean Conflict: 1 November 1950-30 June 1952," USAF Historical Division, Air University, 1953, pp. 100-102, 118-25. Part of a three-volume monograph study of the Korean War written by Frank Futrell, this study served as the basis for Futrell's later book, *The United States Air Force in Korea 1950-1953* (New York: Duell, Sloan and Pearce, 1961). The USAF monographs contain logistics-related information not included in the book.
21. The Air Service maintained a similar system in France during World War I, with the use of air depots located a safe distance from the front lines. See *The U.S. Air Service in World War I*, vol I, *The Final Report and a Tactical History*, ed. Mauer Mauer (Washington, D.C.: Office of Air Force History, 1978), pp. 55, 117-27.
22. Production line third echelon maintenance was tried less successfully with transport aircraft in the China-Burma theater during World War II at the direction of then Brig. Gen. William H. Tunner. See *The Army Air Forces in World War II*, vol 7, *Services Around the World*, ed. Wesley F. Craven and James L. Cate (Chicago: University of Chicago Press, 1958; repr., Washington, D.C.: Office of Air Force History, 1983), pp. 140-41.
23. Carl G. Nelson, Maj. USAF, "REMCO, A Korean War Development," *Air University Quarterly Review* (Summer 1953): 78-85; "United States Air Force Operations in the Korean Conflict: 1 November 1950-30 June 1952," pp. 100-104.
24. "United States Air Force Operations in the Korean Conflict 1 July 1952-27 July 1953," pp. 272-75; "History of the Air Materiel Command 1 July-31 December 1952," pp. 413-15, 540-41.
25. Korean geography and transportation facilities, as of 1950, are described in USAF Historical Study No. 71, "U.S. Air Force Operations in the Korean Conflict: 25 June-1 November 1950," USAF Historical Division, Oct. 1, 1952, pp. x-xiii.
26. The FEAF assigned a K-number designator to each of its airfields in Korea.
27. KAMU organization and support activities are described in "History of FEAMCOM 1 Jul-31 Dec 50," pp. 2-42.
28. The problems of airfield construction are described in USAF Historical Study No. 127, "United States Air Force Operations in the Korean Conflict 1 July 1952-27 July 1953," USAF Historical Division, Air University, Jul. 1, 1956, pp. 172-83.
29. "U.S. Air Force Operations in the Korean Conflict: 25 June-1 November 1950," pp. 18-24; "United States Air Force Operations in the Korean Conflict: 1 November 1950-30 June 1952," pp. 10-16.
30. The activities of the 931st EAG for mid-1951 are described in "Monthly Historical Data Report", AF-DS-U3A, 931st Engineer Aviation Group, Mar. 1951, and subsequent reports for Apr. 1951, May 1951, Jun. 1951, Jul. 1951, Aug. 1951 (AFHRA microfilm, Roll K0169).
31. "United States Air Force Statistical Digest, Fiscal Year 1953," pp. 10-14.
32. The activities of the Engineer Aviation Units are described in Col. R. I. Millberry, "Engineer Aviation Forces in Korea," *Air University Quarterly Review* (Fall 1953): 114-119. FEAF runways, facilities and the vehicles and machinery used in their construction are described in "Vehicles, Air Installations and Aviation Engineer Equipment and Facilities," Air Research and Development Command, Task Group for Base Systems, Jul. 20, 1953 and Aircraft Maintenance and Servicing Equipment and Facilities," Air Research and Development Command, Task Group for Base Systems, Jul. 20, 1953.
33. Maj. Leonard B. Reppert, "The Installation Squadron in Korea," *Air University Quarterly Review* (Spring 1952): 89-97.
34. The FEAF switched to JP-4 in Mar. 1952. Prior to that time, FEAF used JP-1.
35. U.S. Air Force Operations in the Korean Conflict: 25 June-1 November 1950," p. 72; "United States Air Force Operations in the Korean Conflict 1 July 1952-27 July 1953," pp. 178-79. Fuels and equipment used by all services are discussed in "Service Performance of Fuels, Lubricants, and Petroleum Distribution Equipment in the Far East Theater," U.S. Research and Development Board, Committee on Fuels and Lubricants, Washington, D.C., Apr. 1953.
36. "United States Air Force Statistical Digest, Fiscal Year 1953" pp. 47-49.
37. Alling, et al., "History of Air Materiel Command Support of the Far East Force in the Korean Conflict," pp. 37-38.
38. *Ibid.*, pp. 36-37. The USAF also used a Navy 6.5-inch anti-tank aircraft rocket that was derived from the HVAR.
39. "History of FEAMCOM 1 Jul-31 Dec 50," pp. 37-43; "FEAMCOM Mission," p. 5.
40. "Steel Planking," *Air University Quarterly Review* (Summer 1953): 128-32.
41. "Vehicles, Air Installations and Aviation Engineer Equipment and Facilities"; "Aircraft Maintenance and Servicing Equipment and Facilities."
42. Col. Hugh J. Mattia, "Air Force Procurement in Japan," *Air University Quarterly Review* (Fall 1953): 123-27. Because the U.S. could not produce all of the goods needed for MDAP, it turned to foreign, off-shore manufacturers.

Secretaries and Chiefs of Staff of the United States Air Force. By George M. Watson, Jr. Washington, D.C.: Air Force History and Museums Program, 2001. Photographs. Illustrations. Appendices. Index. Pp.viii, 270. \$46.00

It is always pleasant when a work that is obviously essential for reference turns out not only to be well written but beautifully illustrated. Such is the case with *Secretaries and Chiefs of Staff of the United States Air Force*, which author George Watson has rendered with such obvious interest and care.

Much of the success of the United States Air Force over the years may be attributed to the wisdom with which these leaders were selected. In almost every instance—there were some exceptions that Watson candidly relates—the persons chosen to be either secretary or chief of staff proved equal to the ever-changing challenges that arose.

Watson covers the nineteen secretaries and sixteen chiefs in a succinct style that manages to capture not only their backgrounds but their personalities and the essence of their style. His ability to do this stems from his compete command of the events of each person's career. A case in point is his coverage of Harold Brown, secretary from 1965 to 1969. In three short paragraphs, Watson links Brown service as Air Force secretary, as president of the California Institute of Technology and as Secretary of Defense in a manner that provides an immense amount of information about Brown's performance and viewpoint.

The book is enhanced by Watson's ability to link events, as when he cites the similarity of the tasks faced by Verne Orr in 1981 with those of Harold Talbott some thirty years before. This ability also enhances the stories of the individual Chiefs of Staff, for Watson is able to evoke the challenges they faced and their views of the situation in which the Air Force found itself upon their retirement. Thus, in his account of Gen. David C. Jones, he relates not only his achievements as chief of staff, and later as chairman of the Joint Chiefs, but also his continuing efforts after retirement when he labored actively for what became the Goldwater-Nichols Department of Defense Reorganization Act of 1986.

Formal portraits are included for each of the chiefs and secretaries, and these add a great deal to the book. It is interesting to study these portraits after you have read the biographical accounts for you can almost feel the intelligence and character that illuminate them. They add a great deal to the general impression that the book gives that the United States has been very fortunate to have so many good leaders over such a long period of time.

There are five appendixes and an excellent bibliography. A writer or researcher on Air Force subjects will immediately recognize the value of the appendixes, especial

Appendix IV, which lists the promotions, assignments and decorations of the Air Force chiefs of staff. This provides a handy reference for fixing these leaders in position and rank for any given date, and gives a quick appreciation of just how varied and extensive experience is required to prepare for the position of chief. Watson even provides a biography of the artists who painted the handsome portraits, a very nice touch indeed.

Walter J. Boyne, Ashburn, Virginia.



Professional Military Education in the United States: A Historical Dictionary. Edited by William E. Simons. Westport, Ct.: Greenwood Press, 2000. Pp. xiv, 391. \$?? ISBN: 0-313-29749-5.

William Simons's book is a useful one-volume encyclopedia of topics relevant to the history and current practice of American professional military education (PME). Its subtitle is somewhat curious, since it is far more than a dictionary; most of the entries are two or more pages long, sources used are cited at the end of each entry, and biographies of the individual authors are given at the end of the volume. The book understates its own scope by not referring to itself as an historical encyclopedia. It is comparable, with a specific focus on PME, to Trevor Dupuy's 1992 *International Military and Defense Encyclopedia*.

The editor has written an excellent introduction that offers an historical perspective on American PME that will be of interest to those who have taught and studied in the system and, perhaps especially, to those who have not. Increasing numbers of civilians from other federal and state agencies and non-governmental organizations now work on a daily basis with United States military officers. The introduction offers insights into the origins of the educational institutions that have produced these officers, and the individual entries provide in-depth information on specific topics. A brief "editor's postscript" concludes the volume with some thoughts on issues confronting PME today.

The book is usefully organized, as its subtitle implies, alphabetically, so that the reader who wishes to go directly to the entry for "The Basic School" or "The School of Aerospace Medicine" can do so quickly. It also contains a thorough and easy-to-use index, list of acronyms and abbreviations, and bibliography. As a reference tool to have on a shelf when the need arises, this book can be highly recommended as a concise authority to those who need to know more about PME.

It is, however, more than that. Happily for the reader, Simons has a broad definition of what is relevant to American PME

and, equally happily, a talent for selecting contributors who write cogently and succinctly on their individual topics. As a result, in a relatively short volume, he has managed to gather a surprising amount of information on a wide range of subjects. These include not only the Gerow Board and the Skelton Panel, to be expected in a thorough treatment of PME, but also biographical entries on such individuals as Claudius Crozet, Matthew Maury, and Justin Morrill; concise historical entries on the host communities of key PME institutions, including Annapolis, New London and Newport (but not Colorado Springs); and entries on historic and contemporary PME institutions abroad, including the RAF College at Cranwell, the Frunze Military Academy, and the Ecole Militaire. The volume is thus both joint and combined in its approach and product.

Simons and his contributors have produced a work of lasting value. This book reflects neither current jargon nor passing fads. Instead, it provides information on the individuals, institutions, and issues that have shaped American PME from the early days of the Republic to today. It deserves a place on the bookshelf of all those interested in the education of generations of American military officers, those who have served, and those yet to come.

From 1995-2001, Edwina Campbell was a professor of grand strategy at the Industrial College of the Armed Forces, National Defense University.



RAF Squadrons: A Comprehensive Record of the Movement and Equipment of All RAF Squadrons and their Antecedents Since 1912. By C. G. Jefford. UK: Airlife Publishing, 2001 [2d edition]. Maps. Photographs. Illustrations. Pp. 290. £40.00 ISBN: 1-84037-141-2

This particular book on Royal Air Force (RAF) squadrons has earned a place in the libraries of air force historians, both official and unofficial. It provides a comprehensive and valuable reference on the movement and equipment of all RAF squadrons and their antecedents since 1912.

It is not for those who prefer a narrative account of a known squadron that they may have served in previously. The author makes no pretense of this and thus the readership is limited and more suitable for specialists seeking background information for research.

The author has produced an amazing amount of information and minute detail on squadron movements, locations, and equipment flown. Most of this information had to be obtained from the Ministry of Defence and the Public Records Office before computerized data was available. He notes that

it has taken him twenty years to assemble and cross check the mass of detail involved C a Herculean task and not for the faint hearted.

In his introduction, Jefford defines the term "squadron" and discusses at some length what comprises a squadron. To most serving or retired RAF personnel, there is little argument as to the perceived definition of a squadron, should it be generated as a formation, unit, or flying squadron. Most would assume that the term meant a flying squadron, especially if—as in the book—the squadron is numbered.

There is also a discussion on centralized servicing—a subject that has promoted strong opinions for and against. It can be argued that the pooling of ground crews saves manpower and well it may. However, the esprit de corps and morale manifested by a squadron with its own ground personnel is an important factor, especially in a combat situation. There is pride in belonging.

The origins of squadron numbers is well covered and of considerable interest as few people in the RAF have been able to understand the rationale for forming or disbanding squadrons. There is always, it would seem, some special case for bending the policy. However, the policy for renumbering squadrons was never well received and was unpopular. Squadrons and organizations that had contributed in a significant manner, particularly in World War II, were disbanded or renumbered for what would appear to be administrative convenience.

In the book's various annexes on locations used by squadrons, aircraft used by squadrons, aircraft manufacturers, and location maps, the cross-referencing and detail provided is outstanding. The research involved is a major work in itself. The author's dedication to the task is evident throughout the volume and evokes admiration and indeed respect from the reader. The location maps are especially valuable, as many of the airfields and landing strips are gone forever. The photographs included are varied and well chosen. The overall impression one gets on reading this book is of an RAF that in its heyday spanned a good proportion of the world in war and peace.

Squadrons can be disbanded by a stroke of the pen. Indeed, after both World War I and World War II the rundown of the RAF was accomplished in a remarkably short time. However, to reform, train, and reach operational status is a lengthy procedure. This was very evident prior to World War II and during the Cold War expansion. Additional squadrons may have been formed by making them smaller, through a reduction of the aircraft complement and personnel. This may have looked better on paper, but it did not increase the total number of aircraft and crews available.

The author of *RAF Squadrons* has produced a first class reference book packed with information, some of which is unique

and little known. It is a valuable chronicle of the numbered flying squadrons—the cutting edge of the RAF.

AVM W. Harbison, RAF (Ret.), Falls Church, Virginia



Wingless Eagle: U.S. Army Aviation through World War I. By Herbert A. Johnson. Chapel Hill and London: The University of North Carolina Press, 2001. Map. Photographs. Notes. Appendix. Bibliography. Index. Pp. xvi, 298. \$34.95 ISBN 0-8078-2627-8

The growth of U.S. Army aviation during its earliest days has been a long-neglected and potentially rewarding subject for historical study. Herbert A. Johnson's *Wingless Eagle* makes a substantial contribution to our understanding of that stage in U.S. military aviation history.

For far too long, writers on the period between 1907 and 1918 have perpetuated the myth of a small band of far-sighted, young airmen committed to building a modern air arm in the face of opposition from reactionary army leaders firmly grounded in the horse and bayonet. Many of us researching in the era, however, have long known that the real story was far more complex. Congressional leaders were a far greater handicap than army commanders, and rivalries between airmen often did more harm than superannuated ground officers. Most important, the lack of an identifiable enemy robbed advocates of the justification they needed for a strong military air arm. Johnson, the Hollings Professor of Constitutional Law at the University of South Carolina and a retired U.S. Air Force Reserve officer, has explored this period based on comprehensive research. Especially, he has mined the holdings of the Air Force Historical Research Agency at Maxwell AFB, Alabama, with spectacular results. The other great strength of *Wingless Eagle* is that the author has avoided a narrow focus on army aviation and set its development in a wider cultural and national context, enabling him to explore topics other books treat superficially, if at all. The result is an excellent and original study.

Several topics covered deserve mention. Especially, the author evaluates the importance of the civilian Aero Club of America and the wider Aeronaut constituency. The existence the Aero Club and an informal collection of aviation enthusiasts often occupying important social and economic positions, facilitated the acceptance of military aviation. Yet, as the author demonstrates, the initial success of these advocates gave way to strident claims that ultimately sacrificed credibility with Congress and the public to the detriment of military aviation.

In similar fashion, *Wingless Eagle* explores the calamitous impact of the patent wars between the Wright brothers and other manufacturers, especially rival Glenn Curtiss. The legal battle over patents limited the progress of U.S. military aviation significantly, as did the interesting fact that U.S. Army officers tended to align themselves with the Wrights, while the U.S. Navy favored Curtiss who demonstrated a successful pontoon-equipped aircraft in 1911. These alliances were significant, since the Wright Company failed to keep pace with progress, while Curtiss produced increasingly more capable aircraft.

Commendably, *Wingless Eagle* also resurrects the story of the courts-martial in October 1915 of Lt. Col. Lewis E. Goodier, the father of aviator Lt. Lewis E. Goodier, Jr. The origins of this incident are complex, but had their roots in the terrible accident record of the Wright Model C aircraft, and in the fact that non flyers, Lt. Col. Samuel Reber and Capt. Arthur S. Cowan, commanded the Aviation Section of the Signal Corps and the Signal Corps Flying School, respectively. Using the courts-martial as a vehicle, the author explores divisions within army aviation and the strong personalities involved.

Johnson treats other significant topics, including the growth of tactical thinking and air power doctrine; the fact that U.S. Army leaders were all too familiar with aviation developments in European military aviation; Congressional and Presidential attitudes, including the important hearings by the Hay and Kennedy Committees; the controversy over the airship versus the airplane and its consequences; the Mexican Punitive Expedition and the National Defense Act of 1916; and the radical expansion of U.S. military aviation during World War I.

Wingless Eagle has its shortcomings. Chief of these is its topical, instead of chronological, organization. World War I, for example, appears twice, first in Chapter 7, and then in an epilogue and prologue, with the chapter on the Punitive Expedition and National Defense Act of 1916 sandwiched in between. The author presents a reasonable explanation for the topical arrangement; however, the approach obscures relationships between events and adds redundancy to the text.

More importantly, while the author correctly recognizes the critical importance of the aviators's personalities and their interrelationships, his topical organization prevents him from exploring that insight in a meaningful, systematic way. Airmen appear and disappear at various times with relatively little explanation for their actions or positions during events. Capt. Paul Beck, to cite one case, advocated an independent air service in 1913, when Benjamin D. Foulois and others still believed that aviation should remain under the Signal Corps. Yet,

who was Beck, and why did he take that position at that time? And what became of him? The evolution of the careers of important individuals including Foulois, Frank Lahm, Billy Mitchell, Edgar S. Gorrell, and Henry H. Arnold and their personal relations played a crucial role in military aviation. They were ambitious rivals for rank and power. Arnold was one of Mitchell's admirers, but distrusted Lahm. Lahm had little respect for Mitchell and probably Foulois, while Mitchell and Foulois hated each other. And it is quite possible that Foulois drove Beck completely out of aviation. Such relationships need systematic study.

To conclude, as I do, that the definitive history of U.S. military history before 1918 has yet to be written should not detract from Professor Johnson's study, however. *Wingless Eagle* makes an original and important contribution to the historiography of the period before 1918. A copy belongs on the shelf of everyone interested in early U.S. military air power.

Roger G. Miller, Air Force History Support Office, Bolling AFB, Washington, D.C.



U.S. Eyes of Artillery: The Origins of Modern Army Aviation in World War II. By Edgar F. Raines, Jr. Washington, D.C.: Center of Military History, 2000. Pp. 372.

The story is rather straightforward. Throughout the 1930s the U.S. Army Air Corps became increasingly involved with bombers, fighters, and the strategic mission. In contrast, it gave decreasing attention to the originating function of air power—air observation for the ground operations. There was a sense in the Air Corps that observation aircraft appeared to be obsolescent in the face of increasingly deadly anti-aircraft firepower of European defenses. But other combat arms of the Army continued to demand air observation and technological improvements. Finally in the early war years, airmen relinquished some control to permit creating a small Army aviation organization. Fast forward a few decades to find that organization, now called the Army Aviation Branch, with more aircraft than its evolved parent, the United States Air Force.

In exquisite detail, Dr. Raines describes the observation aircraft transformation through the early 1940s. Readers will be impressed at the depth of research. This work shows years of reflection, many discus-

sions with military specialists, and exhaustive document analysis. This study is comprehensive as it examines and analyzes all of Army aviation, including organization, administration, doctrine, operations, and technology.

From an Air Force perspective, his magnificent study presents the "other side of the story." It begs the question of whether an Air Force advocate can review fairly to a book that describes and analyzes the ground/air debate. The ground arms won the prize largely because the airmen were preoccupied with other aspects of air power. Raines makes it clear in his preface that his "institutional" study "provides a means of examining the dominant tactical philosophy of the U.S. Army in the twentieth century—combined arms."

On the other hand, if Raines cannot be ultimately non-partisan, he goes to great length to present the case with careful objectivity. He notes that the issue between the Air Corps and the Field Artillery engendered polite debate at first, but became contentious as both sides saw the gaping differences between them. Indeed, "Air and ground officers misunderstood and mistrusted the motives and intentions of the members of the other group," an endemic problem of bureaucratic/service rivalry.

AMERICAN MILITARY UNIVERSITY

www.amunet.edu

ONLINE
electronic classrooms

keep you in touch with other students
and our distinguished, professional faculty.

- ◆ Full ACE credit for training and experience.
- ◆ Convenient, flexible programs that put YOU in charge of your schedule.

- ◆ Undergraduate financial aid and tuition assistance may cover 100% of tuition and book costs!
- ◆ Associate's, Bachelor's, Master's Degree and Certificate Programs including:
 - Military Studies
 - Air Warfare
 - Military History
 - Intelligence
 - National Security Studies
 - Management
 - and 30 other areas...



Breaking Barriers
In Distance Learning

e-mail: info@amunet.edu 1-877-468-6268

Accredited by the Distance Education and Training Council and licensed by the Virginia State Council on Higher Education.



General Arnold argued that there would be insufficient aircraft to fill requirements for all brigades and that light aircraft could not stand up in combat. A compromise allowed each division an observation squadron.

Raines characterized the Air Corps as having excessive power and influence, illustrating his view by analyzing the equipment budget figures of 1931. It has the appearance of being a good case study because it compared Air Corps millions to ground force thousands. The Air Corps got some \$36 million; the Infantry received only \$65,000, the Field Artillery \$20,000, and the Cavalry \$26,000. Raines points out rightly that this disparity "was not autonomy...but its size in comparison to the other branches did represent a substantial measure of power within the narrow confines of the War Department." What he fails to say is that this funding disparity can be explained partly by the existence of surplus war World War I equipment that was still useful for all the combat branches save the Air Corps.

The extensive analysis in this book speaks to current air power issues. While other combat arms favored the low technology air solution, the Air Corps had a passion for cutting-edge technology. Another issue was the airmen's preference for future capa-

bility, contrasted with the Army's older leaders, who focused on existing capabilities. It produced gridlock in the War Department over the establishment of organic light aviation for the ground forces.

How did the Artillery finally win the battle? Raines suggests it was through the successful exploits of "thousands of air-observation-post pilots, mechanics, and observers." Battle gave it the right to exist. And second, the organization was fully approved at the end of World War II by top-level military leaders who unequivocally supported organic air for the ground forces.

Raines is not completely persuasive on the issue of the vulnerability of light airframes to enemy air and ground weapons, long considered sufficient reason by the airmen to ban them from the battlefield. Combat operations did indeed show that these light observation aircraft were excessively vulnerable to enemy fighters and ground fire. Raines admits "light-aircraft pilots feared the Luftwaffe more than any other threat, but...rarely had to face German pursuits." However, the fact that the Allies won air superiority does not discount the airmen's argument. Airmen in the 1930s had not foreseen the quantities of aircraft they would in World War II.

The Air Force viewpoint is further exaggerated if we remember the issue advocated by John Ellis in *Brute Force, Allied Strategy and Tactics in the Second World War*; that the United States helped the Allies win by having so much equipment. Tactical air power worked like a charm in Normandy and later, but only because the United States had so much that it could, in 1930s wisdom, employ aircraft in wasteful and ineffective manner. Raines addresses the issue obliquely when he suggests that "In the simplest possible terms, the U.S. Army gained its own organic aircraft during World War II because of supply and demand." The almost complete air superiority held by U.S. air power since 1944 has assured that ground forces can employ light aircraft and helicopters. For all the danger still apparent, it is necessary to have, at least, freedom from attack from above.

This is a great book that helps airmen understand their history. The classical service debates are fully discussed here and will encourage a more honest evaluation of modern military air power.

Dr. Daniel Mortensen, SAAS, Maxwell AFB, Alabama.



AIR UNIVERSITY PRESS

Your Air & Space Power Publisher

Publications on Aerospace Doctrine,
Strategy, and History • Biographies of Pioneer Airmen

131 West Shumacher Avenue
Maxwell AFB AL 36112-6615
For catalog or information, call
334-953-2773/6136 DSN 493-2773-6136
Fax 334-953-6862 Fax DSN 493-6862
<http://www.au.af.mil/au/oas/aupress>

Currently Seeking Manuscripts



AUPRESS

The Last Battle: The Mayaguez Incident and the End of the Vietnam War. By Ralph Wetterhahn. New York: Carroll & Graf, 2001. Maps. Photographs. Notes. Appendices. Index. Pp. ix, 384. \$27.00 ISBN 0-7867-0858-1.

On May 12, 1975, Khmer Rouge forces seized the *Mayaguez*, a U.S. merchant ship steaming in international waters. This event precipitated a rescue operation that resulted in the deaths of forty-one American and twenty-five Khmer troops. Ironically, just as the rescue commenced, the Khmer leadership in Phnom Penh decided to release the ship and the crew, rendering the entire attack unnecessary. In the end, U.S. Marines wound up in a useless and bloody assault against Koh Tang, a heavily defended Cambodian island with no hostages on it.

Ralph Wetterhahn, a journalist and a retired Air Force fighter pilot, offers the most readable account of this final chapter in the Vietnam War yet published. However, his book presents only a few new details not covered either in Roy Rowan's *The Four Days of Mayaguez I* (Norton, 1975) or John Guilmartin's *A Very Short War: The Mayaguez and the Battle of Koh Tang* (Texas A & M, 1995). Wetterhahn's criticisms of micro-

management from Washington, the lack of proper training of the helicopter crews, and poor communications between Marine ground troops and Navy fighters mirror those made by Guilmartin. In fairness to Wetterhahn, he does praise Guilmartin, Rowan, and several other authors in his acknowledgements for laying the groundwork for his study, but does not mention that these books are his major sources—something which only becomes apparent after examining his notes. Wetterhahn only interviewed a handful of survivors and did little archival research beyond looking at some material in the Ford Library.

What is fresh about *The Last Battle* is the research Wetterhahn conducted in Cambodia while traveling with a detachment of Joint Task Force Full Accounting (JTF-FA) in search of the remains of U.S. servicemen at Koh Tang. Through an interview with the former Khmer officer in charge of the battalion defending Koh Tang island, Wetterhahn reconstructs the battle as seen from Cambodian side. He also reveals chilling details about the fates of three Marines inadvertently left behind during the withdrawal from Koh Tang—an event never mentioned in the earlier accounts. Finally, the author's reporting on the activities of

JTF-FA provide a fascinating glimpse at the extraordinary efforts the U.S. government undergoes to account for its missing service personnel.

This reviewer recently discovered a cache of thirty-three interviews of Marine personnel involved in the *Mayaguez* incident held by the Marine Corps Historical Center. Ralph Wetterhahn intends to incorporate these interviews in a revised version of the *Last Battle* to be published in paperback by Penguin Putnam. In its second edition, *The Last Battle* will not only be best written and most accessible account of the incident but also the definitive history as well.

Dr. John Sherwood is a historian at the Naval Historical Center and the author of Fast Movers: Jet Pilots and the Vietnam Experience (St. Martin's, 2001).



Reconsidering Sputnik: Forty Years Since the Soviet Satellite. By Roger D. Launius, John M. Logsdon, and Robert W. Smith, eds. Amsterdam, The Netherlands: Harwood Academic Publishers, 2000. Ta-

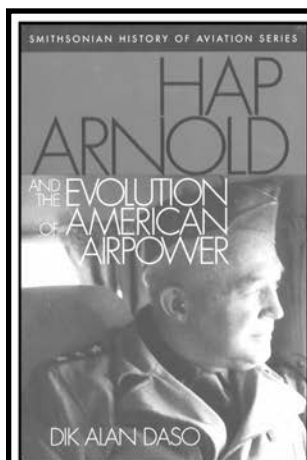

Hap Arnold and the Evolution of American Airpower

Dik Alan Daso

How the peacetime experiences of World War II's foremost military aviator shaped the evolution of American military aviation. Winner of the History Manuscript Award from the AIAA.

80 b&w photos • 368 pp. • Paperback \$17.95

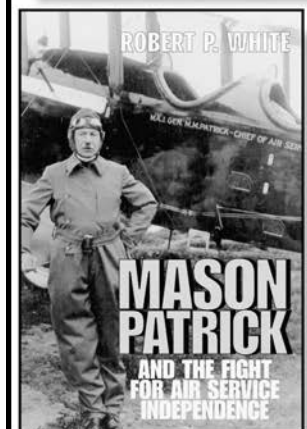

Mason Patrick and the Fight for Air Service Independence

Robert P. White

A full assessment of Patrick's aviation career, crediting him (and not Billy Mitchell) with ensuring the survival of the Air Service and the eventual emergence of an independent Air Force.

16 b&w photos • 208 pp. • Hardcover \$24.95



Smithsonian Institution Press

800.782.4612 • Also available at bookstores

bles. Illustrations. Notes. Appendices. Index. Pp. xx, 443. \$58.00 ISBN: 90-5702-623-6

The Soviet Union launched *Sputnik 1*, the world's first artificial satellite, on October 4, 1957. To commemorate the fortieth anniversary of this watershed event, the NASA History Office and several co-sponsors put together a highly praised symposium involving more than 150 participants from around the world, plus some thirty media people. Papers from that meeting, which occurred on September 30 and October 1, 1997, in Washington, D.C., along with additional research studies, have been assembled by editors Roger Launius, John Logsdon, and Robert Smith into a volume titled *Reconsidering Sputnik: Forty Years Since the Soviet Satellite*. This cohesive, comprehensive collection of essays is among the first to appear since the end of the Cold War and the resultant opening of valuable archives on both sides. Consequently, it affords new perspectives on the planning for the world's first satellite launch, as well as the immediate reactions to, and long-term consequences of, that event.

The book contains thirteen, individually authored chapters divided among three parts, which are sandwiched between a reflective introduction by historian Walter McDougall and a thought-provoking epilogue by political scientist Glenn Hastedt. Professor McDougall, Pulitzer Prize-winning author of *...The Heavens and the Earth* (1985), revises his earlier conclusion that the chain of events kicked off by Sputnik was a "saltation." Titled "Space Flight in the Soviet Union," Part 1 proceeds with Peter Gorin's interesting analysis of Soviet public perceptions of space flight prior to the launch of *Sputnik 1*. Essays by Asif Siddiqi and James Harford follow with enlightening discussion of "the institutional and political machinations behind the genesis of Sputnik" and of Sergey Korolev's central role in overseeing the development of *Sputniks 1, 2, and 3* to satisfy Premier Nikita Khrushchev's increasing demands. Finally, William Barry describes the hybrid Soviet space industry—an impenetrable maze of bureaus, centers, associations, and other organizations—that emerged during the late 1950s. As editor Launius points out, these four contributions "complement each other in showing the duality of military and civil priorities for space, the relationship of popular culture and public policy, and the intense nastiness of the cold war struggle" between the Soviet Union and the United States.

In Part 2, "A Setting for the International Geophysical Year," four scholars provide different perspectives on the U.S. reaction to the Soviet satellite. Describing the satellite portion of the IGY as "at best a mating of scorpions," Rip Bulkeley marvels that it yielded even "some degree of useful scientific interaction and exchange." Dwayne Day emphasizes that American

strategists viewed establishment of the freedom-of-space principle as more important than being first to launch a satellite. Interpreting the evidence differently, Kenneth Osgood argues that prestige rather than overflight lay at the heart of American space efforts during the IGY. National Air and Space Museum curator Michael Neufeld finds that overflight, national prestige, and concerns about not slowing the pace of critical long-range, ballistic missile development all factored into U.S. selection of the Navy's *Vanguard* program over the Army's *Orbiter*. Based on the disagreements evident in these chapters, editor Smith predicts that finer-grained studies will yield more surprises.

The third part of this skillfully crafted volume extends to the "Ramifications and Reactions" following the Soviet Union's remarkable achievement. Sergei Khrushchev recalls that his father did not recognize the major political significance of *Sputnik 1* until he saw the headlines from newspapers around the world. Reviewing the reaction in Western Europe, John Krige finds that superpower rivalry and NASA's emphasis on international cooperation left little room for independent, third-party action. Eilene Galloway posits the intriguing idea that *Sputnik 1* tipped the scales toward making space a weapons-free environment, with the U.S. being the leading proponent for keeping it that way. John Douglass explains how the Soviet triumph changed the way Americans viewed advanced academic training and research, and Gretchen Van Dyke describes the impact on American politics up through the 1960 presidential election. In a fitting epilogue, Professor Hastedt speculates that the historical impact of *Sputnik* might be understood best by applying the somewhat sophisticated concept of "technological surprise."

Reconsidering Sputnik contains something of value for anyone interested in space history. It presents academic specialists with numerous avenues for further research and reminds avid amateurs that experts often interpret "the facts" differently. While it is neither the first nor the last to examine how the Soviet satellite influenced history, this book is certainly one of the best.

Dr. Rick W. Sturdevant, Deputy Director of History, HQ Air Force Space Command.



Fortress Against the Sun: The B-17 Flying Fortress in the Pacific. By Gene Eric Salecker. Conshohocken, Pa.: Combined Publishing, 2001. Illustrations. Notes. Appendices. Bibliography. Index. Pp. 464. \$34.95 ISBN: 1-58097-049-4

Aviation enthusiasts finally have a book that details one of the less-heralded aspects of World War II's air campaigns. While liter-

ally hundreds of volumes have been written on the B-17 in Europe—particularly with the Eighth Air Force—relatively few discuss the aircraft's combat in the Pacific. Mr. Salecker researched the subject for fifteen years and has produced a work that does justice to these fine aircraft and their crews.

The book is essentially a detailed chronological record of B-17 units and their aircraft and operations in the South and Southwest Pacific areas from December 7, 1941, until their last combat mission on October 20, 1943. Throughout, the author specifies each B-17 involved by tail number and, if applicable, name. The story starts with the twelve aircraft arriving from California during the attack on Pearl Harbor and the subsequent defensive measures around Hawaii. Most of the early chapters, however, center on the 19th Bomb Group's B-17s in their valiant effort to defend the Philippines, the Netherlands East Indies, and Australia. Starting with thirty-five aircraft, half of the aircraft were gone by the end of December 8. Moving to bases in Australia and the Indies, the group held as best it could with just enough replacements coming in to keep operating.

In the offensive following the shoestring defense of eastern New Guinea, B-17s were invaluable in reconnaissance, bombing of shipping, and the isolation of Rabaul. As operations began in the Solomons in August 1942, with the invasion of Guadalcanal, B-17s operating out of the New Hebrides were there adding their punch. But, by mid-1943, it was evident that the day of the B-17 in the Pacific was drawing to a close. Fortresses were needed more in Europe, and the B-24 had the greater range and payload to operate more effectively in the Pacific.

Several general points jump at the reader: A dismal record of hitting moving ships. The theater's terrible weather conditions that constantly upset operations. Absolutely abysmal operating conditions—never enough aircraft; tired, worn-out crews and equipment; deplorable airfields—even in Australia—with flies, mosquitoes, malaria, jungle, and inadequate supplies and services.

The B-17's use as the first U.S. aircraft to do low-altitude skip bombing and even engage in dogfights with Zeros! How few B-17s were shot down by fighters thanks to its legendary ruggedness.

Only two flaws mar this fine book: (1) lack of a list of the generally adequate maps makes dog-earning a necessity for referring to all of the place names mentioned, and (2) at least two instances where captions and photos are reversed. Otherwise, this is a fascinating story of men and equipment operating in the tough early days of the war who did things far beyond what should reasonably have been expected of either.

Col Scott A. Willey, USAF (Ret). Docent, NASM's Garber Facility.

Books Received

Brickhill, Paul. *Reach for the Sky: The Story of Douglas Bader, Legless Ace of the Battle of Britain*. Annapolis, Md.: Naval Institute Press [Blue Jacket Books], 1954; reprinted 2001. Photographs. Index. Pp. 384. \$17.95 ISBN: 1-55750-222-6

Burning, John R. *Jungle Ace: Col. Gerald R. Johnson, the USAAF's Top Fighter Leader of the Pacific War*. Washington, D.C.: Brassey's Inc., 2001. Photographs. Notes. Index. Pp. xxxii, 259. \$26.95 ISBN: 1-57488-357-7

David, James E. *Conducting Post-World War II National Security Research in Executive Branch Records: A Comprehensive Guide*. Westport, Ct. and London: Greenwood Press, 2001. Index. Pp. viii, 266. \$79.00 ISBN: 0-313-31986-3

Doherty, Richard. *Irish Volunteers in the Second World War*. Dublin: Four Courts Press, 2002. Photographs. Notes. Index. Pp. 378. \$29.95 ISBN: 1-85182-523

Hannah, Craig C. *Striving for Air Superiority: The Tactical Air Command in Vietnam*. College Station: Texas A&M Press, 2001. Tables. Illustrations. Photographs. Notes. Bibliography. Index. Pp. 145. \$29.95 ISBN: 1-58544-146-5

Harris, Gary L. *The Origins and Technology of the Advanced Extravehicular Space Suit*. [AAS History Series, Vol. 24] San Diego, Calif.: American Astronautical Society, 2001. Tables. Diagrams. Illustrations. Photographs. Notes. Appendices. Bibliography. Index. Pp. xv, 542. \$60.00 Paperback ISBN: 0-87703-482-6

Mets, David R. *The Long Search for a Surgical Air Strike: Precision Munitions and the Revolution in Military Affairs*. Maxwell AFB, Ala.: Air University Press, 2001. [Cadre Paper No. 12] Photographs. Illustrations. Notes. Bibliography. Index. Pp. xiii, 79. ISBN: 1-58566-096-5 [<http://research.maxwell.af.mil> "research papers" then "special collections"]

Nichols, John B. and Barrett Tillman. *On Yankee Station: The Naval Air War over Vietnam*. Annapolis, Md.: Naval Institute Press [Blue Jacket Books], 1987; reprinted 2001. Photographs. Notes. Appendices. Index. Pp. xvii, 179. \$15.95 ISBN: 1-55750-495-4

Pogue, Forrest C. *Pogue's War: Diaries of a WWII Combat Historian*. Lexington: The University Press of Kentucky, 2001. Illustrations. Photographs. Notes. Glossary. Index. Pp. xviii, 411. \$29.95 ISBN: 0-8131-2216-3

PROSPECTIVE REVIEWERS

Anyone who believes he or she is qualified to substantively assess one of the new books listed above is invited to apply for a gratis copy of the book. The prospective reviewer should contact:

Col. Scott A. Willey, USAF (Ret.)
3704 Brices Ford Ct.
Fairfax, VA 22033
Tel. (703) 620-4139
e-mail: scottville@aol.com

Prados, John. *Combined Fleet Decoded: The Secret History of American Intelligence and the Japanese Navy in World War II*. Annapolis, Md.: Naval Institute Press, 1995. Maps. Illustrations. Photographs. Notes. Glossary. Bibliography. Index. Pp. xxvi, 832. \$27.95 Paperback ISBN: 1-557-50431-8

Sinnott, Colin. *The Royal Air Force and Aircraft Design, 1923-1939: Air Staff Operational Requirements*. London and Portland, Ore.: Frank Cass, 2001. Photographs. Notes. Appendices. Glossary. Bibliography. Index. Pp. xiii, 249. \$54.50 ISBN: 0-7146-5158-3

Sweeting C. G. *Hitler's Squadron: The Fuehrer's Personal Aircraft and Transport Unit, 1933-45*. Washington, D.C.: Brassey's Inc., 2001. Tables. Diagrams. Illustrations. Photographs. Notes. Appendices. Glossary. Index. Pp. xxxii, 259. \$26.95 ISBN: 1-57488-357-7

Teller, Edward with Judith Shoolery. *Memoirs: A Twentieth Century Journey in Science and Politics*. Cambridge, Mass.: Perseus Publishing, 2001. Notes. Appendices. Index. Pp. xii, 628. \$35.00 ISBN: 0-7328-0532-X

Watson, George M., Jr. *Voices from the Rear: Vietnam, 1969-1970*. : Xlibris Corp., 2001. Photographs. Glossary. Pp. 322 \$32.00 ISBN: 0-7388-6314-9

Wilson, Jim. *Combat: The Great American Warplane*. [Popular Mechanics] New York: Hearst Books, 2001. Tables. Diagrams. Illustrations. Photographs. Index. Pp. 192. \$30.00 ISBN: 1-58816-064-5

Xu, Guangqiu. *War Wings: The United States and Chinese Military Aviation, 1929-1949*. Westport, Ct. and London: Greenwood Press, 2001. Map. Notes. Bibliography. Index. Pp. viii, 250. \$64.95 ISBN: 0-313-32004-7

History of Rocketry and Astronautics

Donald C. Elder and Christophe Rothmund, Editors



AAS History Series, Volume 23

IAA History Symposia, Volume 15



HISTORY OF ROCKETRY AND ASTRONAUTICS BOOK SERIES

American Astronautical Society History Series

For a complete listing of these excellent volumes on the history of rocketry and astronautics, including brief descriptions of each volume, tables of contents of most of the volumes and ordering information, please visit the following pages in the book sections of our Web Site:

1. http://www.univelt.com/Aasweb.html#AAS_HISTORY_SERIES
2. http://www.univelt.com/Aasweb.html#IAA_PROCEEDINGS_HISTORY_ASTRONAUTICS_SYMPOSIA
3. <http://www.univelt.com/htmlHS/noniaaahs.htm>

If you would like for us to send you more information, then please contact us as follows:

**Univelt, Inc., P.O. Box 28130,
San Diego, CA 92198, USA
Tel.: (760) 746-4005; Fax.: (760) 746-3139
E-mail: 76121.1532@compuserve.com**

Web Site: <http://www.univelt.com>

Coming Up



Compiled by George Cully

Time in April to be Determined

A symposium on the **Falklands War** and its consequences entitled *The Falklands/Malvinas Conference: Twenty Years On* will be held in Portsmouth, England. Contact: Dr Lucy Noakes, faculty of Media, Arts and Society Southampton Institute East Park Terrace Southampton, Hampshire SO14 0RF United Kingdom e-mail: lucy.noakes@solent.ac.uk

April 4-7

The **Society for Military History** will hold its 69th annual meeting at the Monona Terrace in Madison, Wisconsin. This year's theme is "War and Remembrance: Constructing the Military Past and Future." Contact: Jerry Cooper Department of History University of Missouri-St. Louis Tel.: (314) 516-5735 Website: <http://www.smh-hq.org>

April 11

The **Society for History in the Federal Government** will hold its annual meeting at the Library of Congress, Jefferson Building, Washington, DC. The program will be "A Dynamic Relationship: The Federal Legislature, Executive and Judiciary in Operation." Contact: Ray Smock, SHFG President 6824 Nashville Road Lanham, MD 20706 Tel.: (301) 552-3907, Fax x4907 e-mail: RaySmock@aol.com Website: <http://shfg.org/index.htm>

April 11-12

The **American Institute of Aeronautics and Astronautics** will co-host the 1st AIAA/IAF Symposium on Future Reusable Launch Vehicles in Huntsville, Alabama. Contact: AIAA 1801 Alexander Bell Dr, Ste 500 Reston VA 20191-4344 Tel.: (703) 264-7500, (800) NEW AIAA, Fax 264-7551 Website: <http://www.aiaa.org>

April 11-14

The **Organization of American Historians** and the **National Council on Public History** will co-host their respective annual meetings at the Renaissance Washington Hotel in Washington, D.C. The theme of their joint sessions will be "Overlapping Diasporas: Encounters and Conversions." Contact: Convention Manager Organization of American Historians 112 North Bryan Avenue Bloomington IN 47408-4199 Tel.: (812) 855-7311, fax -0696 e-mail: meetings@oah.org Website: <http://www.oah.org/meetings/index.html>

April 16

The **Military Classics Seminar's** April selection is Wayne Thompson's *To Hanoi and Back: The U.S. Air Force and North Vietnam, 1966-1973*. Washington, D.C.: Air Force History & Museums and Smithsonian Institution Press, 2001. It will be reviewed by Mark Clodfelter. Contact:

Rebecca C. Raines
2307 Candlewood Dr.
Alexandria, VA 22308-1508
(202) 685-2094
e-mail: rainesedandbecky@starpower.net

April 18-20

The **44th Annual Missouri Conference on History** will convene at the Marriott Crowne Plaza Hotel in Kansas City, Missouri. The program will include a special session on the Korean War. Contact: Tim Rives National Archives-Central Plains Region 2312 E. Bannister Rd. Kansas City, MO 64131 Tel.: (816) 823-5031, fax 926-6982 e-mail: timothy.rives@nara.gov

April 19-21

The Annual Meeting of the **Business History Conference** will be held at the Hagley Museum & Library in Wilmington, Delaware. This year's theme will be "Corporate Governance." Contact: Roger Horowitz, Secretary-Treasurer Business History Conference P.O. Box 3630 Wilmington DE 19807 Tel.: (302) 658-2400, x244 e-mail: rh@udel.edu Website: <http://www.hagley.org>

April 24

The **U.S. Naval Institute's** 128th Annual Meeting and 12th Annapolis Seminar will be held in Alumni Hall at the U.S. Naval Academy in Annapolis, Maryland. Contact: U.S. Naval Institute 291 Wood Rd Annapolis MD 21402 Tel.: (410) 268-6110, Fax 269-7940 e-mail: foundation@usni.org Website: <http://www.usni.org>

April 26-28

The 11th Annual Seminar of the **Great War Society** will be held at the Sheraton Newton Hotel in Newton, Massachusetts. This year's theme is "The Russian Revolution, 1917-1921." Contact: Mike Hanlon The Great War Society Box 18585 Stanford CA 94309 Website: <http://www.worldwar1.com/tgws>

May 8-9

Topics for the **Nat'l Naval Aviation Museum's** 2002 Symposium will include "Naval Air War in Korea," "Space Pioneers: The Mercury Astronauts," "Naval Aviation: Issues and Answers," and "Fighters!" Contact: National Museum Of Naval Aviation 1750 Radford Blvd. N.A.S. Pensacola, FL 32508 Tel.: (850) 452-3604 or (850) 452-3606, Fax x3296 e-mail: Naval.Museum@smtp.cnet.navy.mil Website: <http://www.naval-air.org>

May 11-15

The **Army Aviation Association** will hold its annual convention in Nashville, Tennessee. Contact:

AAAA National Office
49 Richmondville Ave
Westport CT 06880
e-mail: aaaa@quad-a.org
Website: <http://www.quad-a.org>

May 16-19

The **Historical Society** will hold its third national meeting in Atlanta, Georgia. This year's theme is "Historical Reconstructions." Contact:

The Historical Society
Attn: 2002 Program Director
656 Beacon Street, Mezzanine
Boston MA 02215-2020

May 20-22

The **American Institute of Aeronautics and Astronautics** will host its 1st Annual Conference and Workshop on Unmanned Aerospace Vehicles, Systems, Technologies, and Operations in Portsmouth, Virginia. Contact:

AIAA
1801 Alexander Bell Dr, Ste 500
Reston VA 20191-4344
Tel.: (703) 264-7500, (800) NEW AIAA,
Fax 264-7551
Website: <http://www.aiaa.org>

May 21

The **Military Classics Seminar** meets for dinner-discussion on the third Tuesday of each month from September through June, at the Ft. Myer, Virginia, Officers' Club, to review outstanding works in military history. This month's selection is Kelly De Vries's *Joan of Arc: A Military Leader*. Phoenix Mill, UK: Sutton, 1999. It will be reviewed by Charles R. Shrader. Contact:

Rebecca C. Raines
2307 Candlewood Dr.
Alexandria, VA 22308-1508
(202) 685-2094
e-mail: rainedandbecky@starpower.net

May 30

The **Journal of Policy History** will host a Conference on Policy History to be held in St. Louis, Missouri. Contact:

Policy Conference
Journal of Policy History
Saint Louis University
3800 Lindell Blvd. P. O. Box 56907
St. Louis, MO 63156-0907
e-mail: dcritchlow@compuserve.com
Website: <http://www.slu.edu/departments/jph>

June 6-7

Siena College is sponsoring its 17th Annual Conference on the 60th Anniversary of World War II. The focus for 2002 will be 1942. Contact:

Professor Thomas O. Kelly, II
Department of History
Siena College
515 Loudon Road
Loudonville, NY 12211-1462
Tel.: (518) 783-2512, FAX 786-5052
e-mail: legendziewic@siena.edu
Website: <http://www.siena.edu/sri/wwii/>

June 11-13

The **American Helicopter Society** will hold its annual convention and exhibition at the Montréal Convention Center, Montréal, Quebec, Canada. This year's theme is "Vertical Flight Technology: Building Global Consensus." Contact:

AHS International - The Vertical Flight Society
217 N. Washington Street
Alexandria, VA 22314-2520
Tel.: (703) 684-6777, Fax 739-9279
e-mail: Staff@vtol.org
Website: <http://www.vtol.org/index.html>

June 18

The **Military Classics Seminar** meets for dinner-discussion on the third Tuesday of each month from September through June, at the Ft. Myer, Virginia, Officers' Club, to review outstanding works in military history. This month's selection is Mark A. Stoler's *Allies and Adversaries: The Joint Chiefs of Staff, the Grand Alliance, and U.S. Strategy in World War II*. Chapel Hill: University of North Carolina Press, 2000. It will be reviewed by David W. Hogan. Contact:

Rebecca C. Raines
2307 Candlewood Dr.
Alexandria, VA 22308-1508
(202) 685-2094
e-mail: rainedandbecky@starpower.net

July 9-11

The **Association For Unmanned Vehicle Systems International** will hold its annual symposium and exhibition at the Disney Coronado Springs Resort in Orlando, Florida. Contact:

AUVSI
3401 Columbia Pike
Arlington VA 22204
Tel.: (703) 920-2720, Fax x2889
Website: <http://www.auvsi.org>

July 10-14

The **Council on America's Military Past** will hold its annual meeting at the Wyndham Old San Juan Hotel in San Juan, Puerto Rico. Contact:

CAMP
P. O. Box 1151
Ft. Myer, VA 22211
Tel.: (703) 912-6124; (800) 398-4693, Fax x5666
e-mail: nereyn@earthlink.net or campart1@aol.com
Website: <http://www.campjamp.org/>

August 6-8

The **Conference of Army Historians** will be held in the Washington, D.C. area. The theme is, "The Cold War Army, 1947-1989." Contact:

Dr. Robert S. Rush
U.S. Army CMH
Attn: DAMH-FPF
103 Third Ave.
Ft. McNair, Wash., D.C. 20319-5258
(202) 685-2727
e-mail: rushrs@hqda.army.mil

If you wish to have your event listed, contact:

George W. Cully
230 Sycamore Creek Drive
Spingboro, OH 45066-1342
(513) 748-4737
e-mail: 71022.1100@compuserve.com

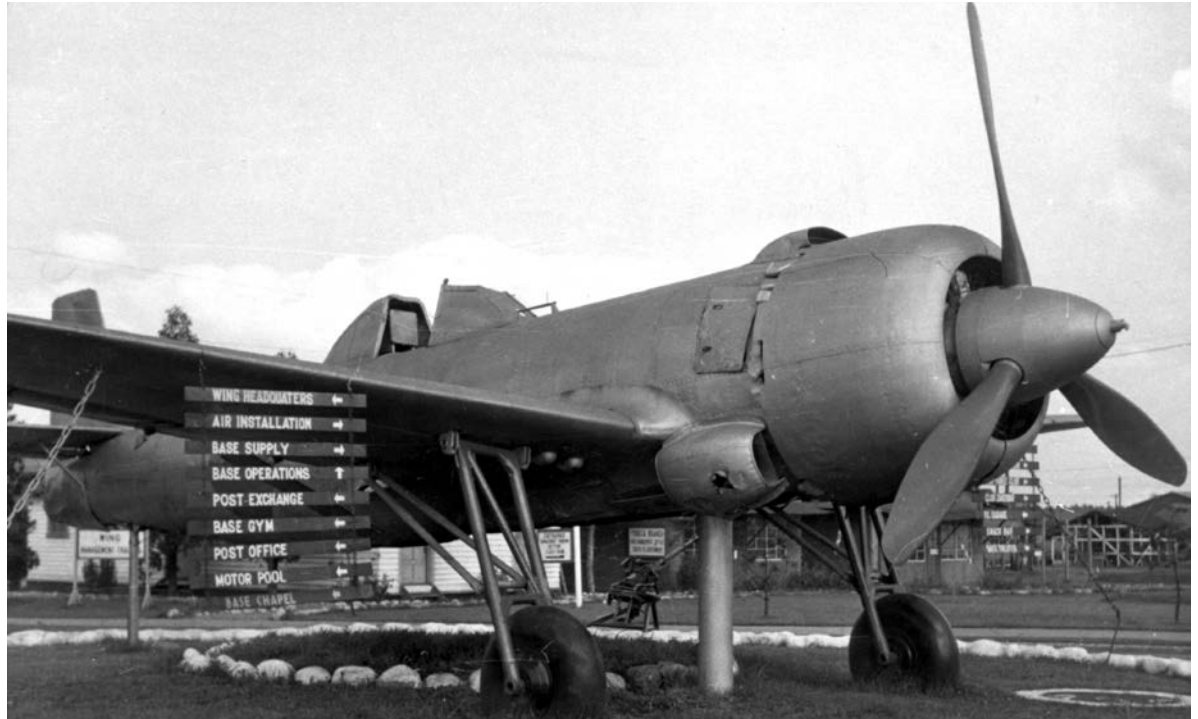

Air Power History has finally outwitted Philip A. Lathrap of Lafayette, California. In the dozen years since APH's "mystery airplane" feature was launched, Mr. Lathrap has been one of the faithful, checking in every quarter with a pinpoint identification of each aircraft on these pages. He identified last issue's History Mystery as a Soviet Lavochkin fighter which "appears to be an La-9 with the modified hood and tail." It's the first time we've sneaked one past him.

The aircraft was, in fact, the Nakajima Ki-115 Tsurugi (Sabre), a desperate attempt by Japan to develop a crude, suicide aircraft in the final days of World War II. Built in 1945, the Ki-115 carried pilot in an open cockpit and had landing gear that dropped free after takeoff. Its 1,100-pound bomb

was intended to detonate when the pilot crashed into his target. Although 104 of these aircraft were—built the first flown in March 1945—it appears none was ever used in combat. When U.S. forces occupied Yokota Air Base near Tokyo in September 1945, six Ki-115s being used in a flight test program became their property.

Between 1945 and 1952, a Ki-115 was displayed at Yokota. This is the Ki-115 seen in our previous issue (in U.S. markings) and in this issue's follow-up photo, kindly provided by Col. Richard Y. Newton.

Only about a dozen readers attempted to identify the Ki-115 and all but one got it right. Our winner this time is Larry Knechtel of Seattle, Washington, who will receive a prize.

This Issue's Mystery Plane

Once again, we challenge our ever-astute readers. See if you can identify this month's "mystery" aircraft. But remember the rules, please.

1. Submit your entry on a postcard. Mail the postcard to Robert F. Dorr, 3411 Valewood Drive, Oakton VA 22124.

2. Correctly identify the aircraft shown here. Also include your address and telephone number, including area code. If you have access to e-mail, include your electronic screen name.

3. A winner will be chosen at random from the postcards with the correct answer. The winner will receive a recently-published aviation book as a prize.

This feature needs your help. In that attic or basement, you have a photo of a rare or little-known aircraft. Does anyone have color slides?

Send your pictures or slides for possible use as "History Mystery" puzzlers. We will return them.



Letters

Give the C-130 Its Due

Betty Raab Kennedy's AMST piece [*Air Power History*, Vol. 48, No. 4, pp. 28-39] was quite interesting, and I, for one, am overjoyed that we have the C-17 in the inventory. However, the author doesn't give the C-130 its due. Her statement "Nor was the C-130 highly regarded as a STOL capable aircraft" doesn't bear close inspection. Granted, the Hercules wasn't designed as a STOL aircraft, but in the literal meaning of short takeoff and landing one can hardly ask for more from an airplane of its size. (The only sizeable non-STOL designed airplane I have flown which could better the C-130s ability is the Grumman Albatross amphibian, a smaller machine with a dissimilar mission.) Runways in Vietnam were classified as Type 1, 2, and 3 for each airlift aircraft, C-7, C-123, and C-130—Type 1 being the minimum. For the C-130, Type

1 was 2,500 feet long, not 3,500 feet as Kennedy states, while 3,500 feet was Type 3 for all three craft. I have landed and stopped C-130Es on a variety of badly surfaced short peapatches, mostly in Vietnam. Coming to a dead stop at the midpoint of 3,000 feet of runway, for example, is nothing exceptional for a reasonably qualified Herk pilot.

A minor technical point: Kennedy refers to "the A and B models." So have I referred to that final letter, so has every other pilot in just about every Air Force airplane. But cursory inspection of various aircraft forms will show the abbreviation "T/M/S," for "Type/Model/Series." For the Hercules I flew, the type is C, the model is 130, and the series is E. Of interest to rivet-counters and academics, mostly. Also makes a pretty good basis for bar bets.

Col. Robert J. Powers, USAF (Ret.)

AMST Author Replies

I believe the C-130 has been a very good aircraft, and we now have the

C-130J-30. If I were a true, diehard C-130 pilot, I would probably have launched an attack on the sentence in question, but I'm not. The historian in me was providing the historical context for justifying an AMST acquisition.

People wanted more—especially in STOL landing—somewhere around 1,500 to 2,000 ft., according to Gen. William W. Momyer.¹ "Basically the problem is range and payload with the light transports, and takeoff and landing performance of the C-130," a TAC briefer told Congress in 1970.² The action officers who worked on the AMST program and drafted the requirement and concept documents were tactical airlifters—mostly C-130 pilots who had flown in Vietnam. They wanted more: "The C-130 has been the heart of the tactical airlift system; however, the aircraft is severely limited in Short Takeoff and Landing (STOL) performance, ground flotation, speed, and cargo compartment size."³

The present medium tactical transport is the Lockheed C-130. Since its entry into



FIRST HAND ACCURACY... AIR WAR/PRISONER OF WAR HISTORICAL NOVEL.

There are a few great novels of the air war. This is one of them. -Robert Morris, Historian

A new concept: Novel with a one hour CD of authentic music, rare recordings, live scenes, and narration to bring pages alive.



The author hews to the facts with no exaggeration. I recommend it to participants in, or students of, the bomber offensive. It may raise painful images, but those are the ones we should not allow ourselves to forget.

-Richard G. Davis, Air Force History Support Office, Washington, D.C.

Memorial Edition:

Limited to 2000 Bonded-Leather books, signed and numbered.

Novel with CD: \$40 plus \$5 s/h Order Toll Free 1-800-996-0772 or by web site www.petalsoffire.com

VISA, MASTERCARD, or CHECK Millennium Memorial Trust, Inc. P.O. Box 1273 Roseburg, OR 97470

Created by WebMediaExpress

the inventory in 1956, it has been operated as both a strategic and a tactical transport. The C-130 was not designed for maximum performance, STOL landings and cannot meet the STOL or California Bearing Ratio (CBR) ratings needed to adequately support forward area mobility requirements. Forward area support with the C-130 has resulted in hazardous operations. Basic safety criteria, such as critical field length and minimum control speeds, have of necessity been routinely discarded in order to provide even minimal payloads into runways 3,000 ft. and under. While aerial delivery (parachute) techniques have allowed delivery of certain types of supplies and equipment by the C-130 in forward areas, airlanding is preferred by all the services in order to

reduce assembly time for troops, reduce equipment damage, and provide for return loads that produce more cost effective aircraft utilization.⁴

I know that C-130s perform better than their given specs, and the C-130s were life savers in Vietnam. But, in testing, the YC-15 did land in 2,100 ft., and the YC-14 achieved 800 and 1,500-ft. landings. The C-17 set a STOL payload and altitude world record on June 3, 1994, when a P-2 carried 44,088 lbs. to an altitude of 6,562 ft. On this occasion, the P-2 took off in 1,369 ft. and landed in 1,356 ft.⁵ Current C-17 specs state the aircraft will land in 2,700 ft. with a 166,965-lb. payload.⁶ Placing this against the real world, for example in Bosnia, the

C-17 and C-130 flew into Sarajevo. Although 8,530 ft. long, the runway only had a useable length of 5,860 ft. According to Lt. Col. Joseph Reheiser, with only a few forklifts, it was taking the French 30 minutes to unload a C-130, carrying four pallets, weighing some 34,000 lbs. When the French got word to expect a C-17 with eighteen pallets, they scheduled an hour ground time. The C-17, however, discharged its 154,000-lb. load and was airborne again in 31 minutes after touching down.⁷ Again in Kosovo, the C-17 would bring in three to four times the load of a C-130 into the small airfield at Tirana, Albania. A comparison of the deployment statistics between the C-130s and the twelve TACON'd C-17s is especially interesting. Between the two, the C-17 performed 67.5 percent of the missions, transported 68.9 percent of the passengers, and hauled 93.7 percent of the cargo.⁸ The C-17's outsize cargo hauling capabilities, which the C-130 does not have, was coming into play here with the task force movements. Yet, within their capabilities, C-130s performed well in Bosnia and Kosovo.

With regard to the issue of semi-prepared and unprepared runways, we all need to remember that we are essentially dealing with dirt, and both the C-130 and C-17 have limitations on such runways, albeit the C-17 would carry in three to four times as much, plus outsize cargo, in just one landing. However, the C-17 would probably incur more FOD than the C-130.

The C-17 is truly an awesome dual-role airlifter, and we will have both the C-17 and the C-130 for many years to come—each building upon its historical accomplishments. I want those who develop the next airlifter after the C-17 to do so grounded in the past, but also open to other possibilities. I have tremendous respect for those who served on the AMST and C-X/C-17 task forces for being visionaries and tenacious.

Betty R. Kennedy

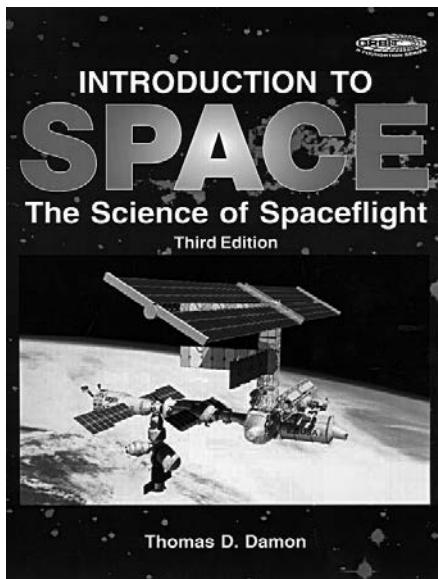

**INTRODUCTION
TO SPACE:
The Science of
Spaceflight, 3rd Ed.**
by **Thomas D. Damon**
3rd. Ed. 2001 326 pp.
Cloth \$57.50
Paper \$49.50

“Tom Damon provides for you, the reader, a lucid understanding of the science and technology of entering space, what we are finding, and some of

our plans for the future. Enjoy it! It’s an extraordinary treatment of an exciting subject, an outstanding introduction to mankind’s greatest, open-ended adventure”—

Edward G. Gibson, Astronaut, Skylab 4

Krieger Publishing Company
P.O. Box 9542 • Melbourne, FL 32902-9542
Call 800-724-0025
E-mail: info@krieger-publishing.com
Fax: 321-951-3671

1. Ltr., Gen. William W. Momyer to Gen. Jack J. Catton, [Air Staff CDP on V/STOL LIT], Dec. 12, 1969.
2. Hngs, House, Military Airlift: Hearings before Subcommittee on Military Airlift of the Committee on Armed Services, 91st Cong., 2d sess, 1970, 6392.
3. Document, HQ TAC, Required Operational Capability For Medium STOL Transport (TAC ROC No. 52-69), May 1970, p 1.
4. Ibid., pp 2, 3.

5. List, National Aeronautic Association, [World Records], Jun 1996; Point Paper, HQ AMC/TEA, "C-17 World Records," May 12, 1995.
6. *C-17 First Look Aircraft Systems Handbook* (USAF Air Mobility Warfare Center, May 1995), p I-3.
7. Article, "Making The Grade In Bosnia," *Aviation Week & Space Technology*, Aug. 19, 1995, p S3.
8. Briefing, Maj Martin Beard, USAFE/AMOCC, "Allied Force: Intra-Theater Air Mobility," Sep. 1999.

More Slangage

Since I served in England from 1966 to 1969, I found the listing of English slang terms of interest. I do have one addition and two possible corrections.

The word "do" was for an event, such as, "a big do at the club." It was still used when I served in England, and sometimes I still use it. A "dustbin" was a trash can, and the men who emptied the containers were called "dustmen." Also, a F/Sgt. told

me that "codswallop" was fish residue at the bottom of a ship's hull that had mixed with seawater. It gave off a foul odor and looked terrible to boot.

MSgt. David W. Menard, USAF (Ret.), Huber Heights, Ohio

Operator Error!

While spell-checking the article, "Aeroplanes of Lebedev's Factory," by Viktor Kulikov [APH, Vol. 48, No. 4], your editor hit the wrong key and thereby changed the French airplane designer's name from Deperdussin to Depredation. Mea culpa.

Defending Switzerland

In her review of Stephen Tanner's book, *Refuge from the Reich: American*

Airmen and Switzerland during World War II [Air Power History, Vol. 48, No. 4, Winter 2001], Dr. Edwina Campbell refers to the "ambiguity of Swiss neutrality."

I am a member of the *Arbeitskreis gelebte Geschichte* (Working Circle of Lived History), an association including retirees of the Swiss Air Force. Our mission is to straighten out the besmirching of Switzerland's World War II past. Therefore, I take exception to Dr. Campbell's statements concerning Switzerland and her criticism of what Tanner has to say.

Swiss neutrality during the war was not ambiguous. Being surrounded by Axis powers it was unavoidable and a matter of survival to do some business with Germany. Switzerland needed permission to transport food across Nazi-occupied territory, and to obtain German coal for its industries and homes. For a while, Swiss manufacturers were on an Allied "black list." With few exceptions, the Swiss people hated the dictatorships surrounding their nation, and greatly enjoyed welcoming American flyers who were shot down, although their experiences were not always happy. As internees, the Americans felt it was their duty to try and escape through German-occupied France.

Dr. Campbell mentions Sweden, Portugal, and Spain as "neutral" countries. But Sweden was an important supplier of steel for the Nazis and, if I am informed correctly, even once allowed German troops to cross its country on the way to Norway. Portugal was Germany's main supplier of manganese, and Spain was very "partly neutral," with Francisco Franco, another dictator, who had been strongly supported by Hitler's Condor Legion in the Spanish Civil War.

There are a few books which I would recommend to Dr. Campbell: Ewen Montagu's thrilling *The Man Who Never Was* (Lippincott, 1953). It describes how the British fooled the Nazis by dropping a uniformed dead body loaded with false information about a planned landing on the coast of Spain, well knowing that any information would be passed on to the Nazis. Another great book is *Between the Alps and a Hard Place* by Angelo M. Codevilla (Regnery, 2000). Codevilla is a professor of international relations at Boston University and his documentation is as complete as humanly possible. Another best seller here is Stephen P. Halbrook's *Target Switzerland* (Sarpedon, 1998).

Stephen Tanner's book describes an



Air Combat Legends

New book by aviation artist

NICHOLAS TRUDGIAN

Price: \$55.00 + tax

(phone orders welcome)

THE MILL STREET GALLERY

125 Mill Street

Occoquan, Virginia 22125

(703) 490-0782 • www.cliftonart.com

aspect of events at a time when I was an air observer in the Swiss Air Force, so I can at least in part refer to events and experiences that I personally witnessed. The late Col. Geoffrey von Meiss (page 146) was my squadron leader. The crew shot down on June 8, 1940, consisted of two of my friends. Rudolph Rickenbacher piloted the Me-109D shot down on June 4, 1940. His brother Hans crashed on May 5, 1945. Both must have been related to the famous American ace Eddie Rickenbacker, who had Swiss parents and died in Zurich on July 1922. To my mind Tanner's *Refuge from the Reich* is a "good book."

Florian E. Davatz, Minusio, Switzerland

Texas Towers: The Rest of the Story

The story of the early warning radar platforms, anchored some 30 fathoms deep in the Atlantic Ocean, off the northeast coast of the United States, is mentioned in Kenneth Schaffel's *The Emerging Shield: The Air Force and Evolution of Continental Air Defense, 1945-1960*, (Washington, D.C.: Office of Air Force History, 1991, Pp. 219-20). Donald Slutzky, a technical representative with the Burroughs Corp. who serviced computer data on one of these platforms, Texas Tower-4 (TT-4), (see photo above right) seeks to complete the record and correct some minor errors.

In Slutzky's version, on September 12, 1960, Hurricane Donna battered TT-4 with 132 mile-per-hour winds and waves in excess of 50 feet. A Coast Guard cutter,

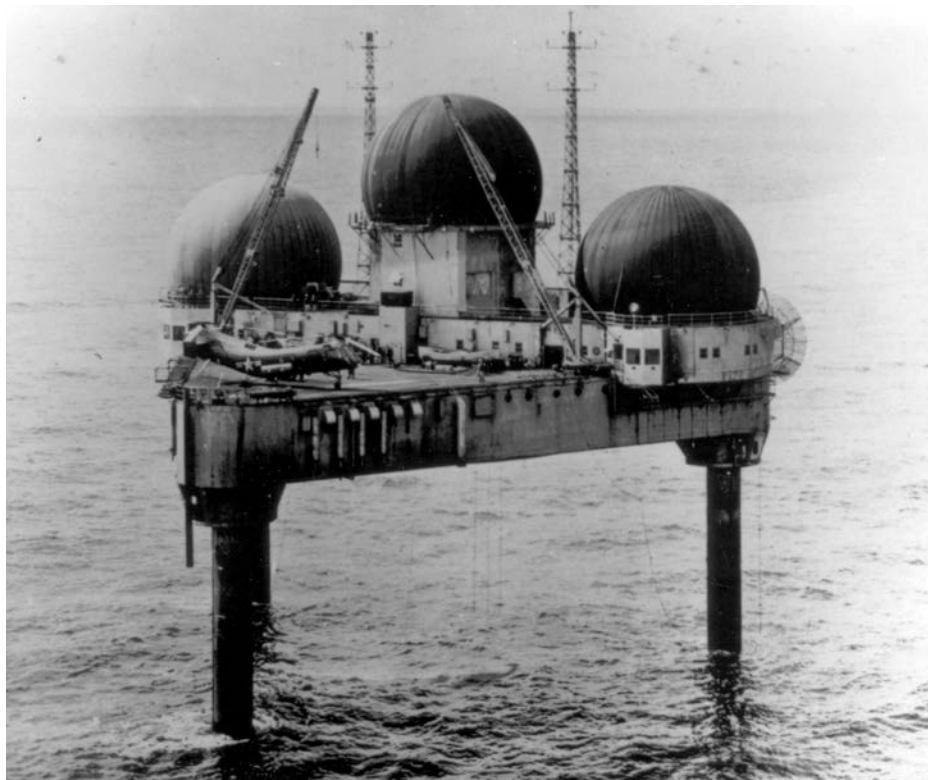

sent to evacuate the military and civilian personnel aboard the tower, was diverted to aid a fishing vessel in distress. By the time that the cutter had returned to TT-4, however, the storm was so fierce that no transfers were possible.

In November, after working for a year on TT-4, Slutzky and others aboard the tower decided to leave, believing that the structure was unsafe. In fact, the extensive damage to the tower forced the Air Force and its construction contractor to

designate February 1, 1961, as the date to begin completely renovating TT-4. Subsequently, the tower's radars were shut down and the full complement of 100 personnel was replaced with a volunteer repair crew of 14 Air Force military and 14 civilian contract maintenance workers. Tragically, on January 15, 1961, a fierce winter gale collapsed the tower and all hands aboard perished. For more complete information on this topic contact: www.texastower.com

Notices

Soviet Spaceflight: Khrushchev's Son Remembers

For those interested in the history of Soviet spaceflight, Dr. Sergei Khrushchev, Senior Fellow at the Watson Insti-

"Champions of Flight"

The Aviation Art of Clayton Knight and William John Heaslip

AVIATION ARTISTS WHO CHRONICLED THE "GOLDEN AGE OF AVIATION" AND THE TRIUMPH OF AMERICAN AIRPOWER IN WORLD WAR TWO

We are seeking original works of art done by these artists during the period, 1926-1946, for an art exhibition that will open in late 2003. If you know of a source willing to lend original works for the exhibition period (approximately 18 months), please contact:

Theodore Hamady

4340 East West Highway, Suite 401 S
Bethesda, MD 20814

Tel: 301 907- 9827 E-Mail: T191418@aol.com

The exhibition will be housed in a secure museum environment and lenders will receive appropriate credit



Flags Of All Nations

Miniature Flags, Lapel Pins,
Custom Design T-Shirts For
Every Occasion

P.O. Box 335763
North Las Vegas, NV, USA
89033-5763

Michael P. Jungers
David A. Jungers

702/ 642-6998
Fax 702/ 642-2080

tute for International Studies, Brown University, has donated materials relating to his father and himself to the John Hay Library at Brown University, Providence, R.I. The Nikita Khrushchev materials include transcripts of dictated reminiscences, edited by Sergei Khrushchev and later published; photograph albums of official visits both within and outside the Soviet Union; and other memorabilia. There are also books, articles, clippings, taped interviews, and various documents pertaining to his role as author and public speaker, both about his father and also about his own circumstances in becoming a naturalized American citizen.

Dr. Khrushchev worked in a Soviet aerospace design bureau during the 1960s and has considerable insight into the workings of the Soviet space program. The total amount of material received so far in this collection amounts to 31 cu. ft. There are some copies of technical reports and working papers on aerospace subjects.

Dr. Khrushchev has his Soviet doctoral degree from the Ukrainian Academy of Science, a Ph.D. from the Moscow Tech-

nical University, and an M.A. with distinction from the Moscow Electric Power Institute. He edited his father's memoirs, *Nikita Khrushchev: Khrushchev Remembers* (1970), *Khrushchev Remembers: Last Testament* (1974), and *Khrushchev Remembers: Tapes of Glasnost* (Little, Brown, 1990). He is also the author of *Khrushchev on Khrushchev: An Inside Account of the Man and His Era, by His Son* (Little, Brown, 1990) and other works.

More information about this collection is available on the Brown University library web link: http://www.brown.edu/Facilities/University_Library/collections/colldev/recent.html

Authors Wanted

Arcadia Publishing, the nation's largest publisher of regional and local photographic history books, is now accepting manuscripts for its new military history series. Some of our past titles include *The Original Hell's Angels: 303rd Bombardment Group of World*

War II, Davisville and the Seabees, The Military History of Boston's Harbor Islands, and Quonset Point Naval Air Station, Volume I and II. We are most interested in publishing modern military history (1850-1975). For more information, please contact editor Tiffany Howe at (603) 436-7610 or visit our website at www.arcadiapublishing.com.

Reunion

The **USS POLLACK (SSN 603) Association** reunion will be held September 11-14, 2002, in Bremerton Washington. Contact:

Dave Schultz
(360) 692-0153
e-mail: dhschultz39@earthlink.net
or
John Lynch
(858) 538-9088
e-mail: j2bubba2

In Memoriam

Col. Vincent T. Ford 1907-2001



Born in Winsted, Connecticut, on September 12, 1907, Vincent T. Ford grew up in California. After earning an engineering degree from UCLA in 1930, he worked briefly as a junior meteorologist, providing weather bulletins to airmail pilots. In 1931, he entered the Aviation Cadet program at Randolph Field, Texas, and the following year won his wings as a pursuit pilot, upon graduation from Kelly Field. In April 1933, he was seriously injured in a mid-air collision while practicing formation flying. The accident sent Lt. Ford to Letterman General Hospital, San Francisco, for more than two years of treatment and rehabilitation. Then discharged as "physically unfit," he was placed on inactive reserve duty.

Subsequently, he worked as a scriptwriter and consultant on aviation films for Universal Studios. In 1942, through grit and perseverance, he managed to return to active duty in the Army Air Forces (AAF) and served in the U.S. and England. After the war, he was assigned to AAF headquarters as military executive for William Burden and Trevor Gardner, officials in the research and development arena. A close associate also of Gen. Bernard A. Schriever, Colonel Ford had a profound influence on weapons acquisition policy. He served on several high-level study groups, notably the 1954 Killian Committee, was detailed to the Executive Office of the President, and sat on the President's Science Advisory Board.

Colonel Ford's preoccupation for more than thirty years was his personal history of the ballistic missiles program. He devoted his energies to this project, which produced a manuscript of more than one thousand pages. Titled "Twenty-four Minutes to Checkmate, 1953-1957," it was donated to the Dwight D. Eisenhower Library in 1992. Colonel Ford retired from the Air Force in 1964. Among his decorations are the Legion of Merit and one Oak Leaf Cluster. He died of cancer on October 21, 2001.

Upcoming Symposium

The Air Force Historical Foundation and Office of the Air Force Historian are sponsoring a symposium, "Coalition Air Warfare in the Korean War," to be held May 7-8, 2002, at the Officers' Club on Andrews AFB, Maryland.

The program features six panels, as follows:

- I. Planning and Operations
- II. Air Superiority
- III. Air Support of Ground Forces
- IV. Air Interdiction and Bombardment
- V. Air Reconnaissance and Intelligence
- VI. Logistical Support of Air Operations

Among the invited speakers are USAF Chief of Staff, General John P. Jumper, Admiral James Holloway, and Air Vice Marshal Paddy Harbison. U.S. Army, U.S. Navy, U.S. Marine Corps, U.S. Air Force veterans, and their Korean War Allies will compare their experiences with the historical perspectives of scholars. The interplay among the groups promises to be illuminating indeed. The audience will participate in question and answer sessions. To reserve seats at this historic event, attendees are urged to complete and mail in as soon as possible the registration form below.

REGISTRATION FORM 2002 Symposium REGISTRATION FORM
COALITION AIR WARFARE IN THE KOREAN WAR
Army, Navy, Air Force, Marines, Allied and Adversary Participants
May 7-8, 2002, Andrews Air Force Base Officer's Open Mess

Name: _____ Affiliation: _____ Address: _____ City: _____ State: _____ Zip: _____	Registration Luncheon (May 7) . Dinner (May 7)	Cost X X X	\$60 \$20 \$30	Amount = _____ = _____ = _____
--	---	---	---	---

SPECIAL SYMPOSIUM REGISTRATION OFFER: Capts., Lts., and enlisted personnel who register in advance may attend seminars free of charge if in uniform. Nonmembers who register and pay may sign up for a special 3-year membership in the Foundation for the price of two (\$70); under 35, 3 years for \$60. Those attending only the luncheons and/or banquet need not pay registration/symposium fee. Spouses and friends are also invited to attend all functions.

Make checks payable to the **Air Force Historical Foundation**
 Please charge to my [Visa [Mastercard [Discover

Send to: Air Force Historical Foundation 1535 Command Drive, Suite A-122 Andrews Air Force Base, MD 20762-7002 Phone (301)736-1959, DSN 858-2139, FAX (301) 981-3574 Email: afhf@earthlink.net	Card #: _____ Expires: _____ Signature: _____
---	--

